

No. 11-111  
February, 1999

Char-Lynn®  
Spool Valve Hydraulic Motors



W Series Geroler® Motors

We Manufacture

Solutions

Hydraulics

Char-Lynn

S

C

h

y

i

d

r

a

u

n

i

c

s

a

c

s

s

r

d

y

H

S

o

i

t

i

o

n

s

Hydraulics

## W Series Gerolër Motors

We Manufacture

Solutions

# Serving Customers Worldwide

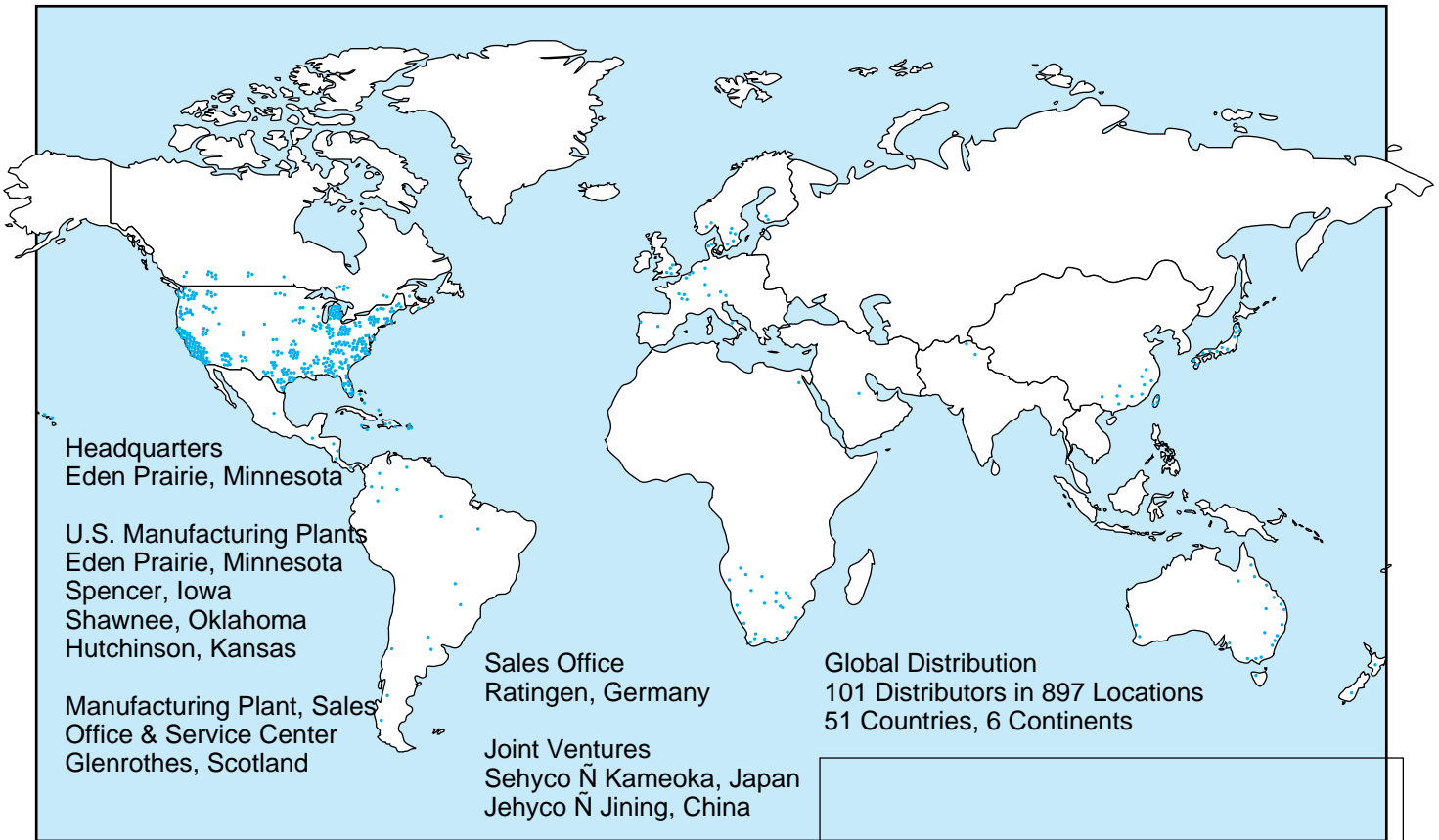

The Hydraulics Division of Eaton Corporation...  
...is your one-stop source for all your hydraulic design and application needs. From world-class engineering capabilities in system design assistance to comprehensive service and technical support after the sale, we are committed to one clear objective Ñ to help assure your complete satisfaction with our products.

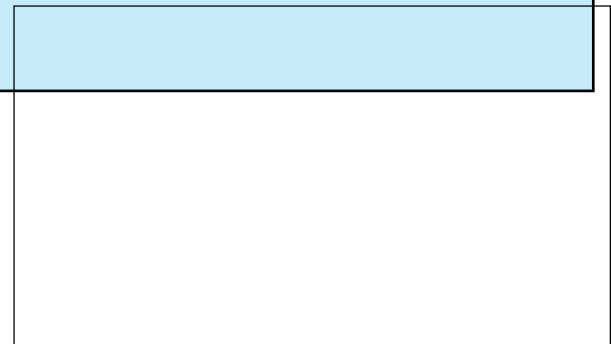

Hydraulics Division Headquarters, Eden Prairie, Minnesota

The Hydraulics Division manufactures and globally markets a complete line of reliable, high-efficiency hydraulic components and systems, including:

- ¥ Hydrostatic Transmissions
- ¥ Electronic Controls and Systems
- ¥ Axial Piston Pumps and Axial Motors
- ¥ Radial Ball Piston Pumps
- ¥ Fully Fluid-Linked Hydrostatic Power Steering
- ¥ Char-Lynn Gerotor and Geroldrow Speed/High Torque Motors
- ¥ Valves, Cylinders, Gear Pumps, and Gear Motors.

#### Major Markets Served

- ¥ Agriculture
- ¥ Construction
- ¥ Fishing
- ¥ Lawn and Garden
- ¥ Mining
- ¥ Marine
- ¥ Industrial
- ¥ Lumber
- ¥ Food Processing

#### Eaton Corporation

Founded in 1911 to manufacture truck axles, Eaton now produces more than 40,000 different products, made in 24 countries on five continents. To serve your current and emerging business needs, Eaton Corporation has over 52,000 employees in 150 manufacturing sites worldwide.

Backed by the most extensive distributor network in the fluid power industry, the Eaton Hydraulics Division has the resources to meet your needs. The Division has four manufacturing plants in the U.S., and one in Scotland. Joint ventures in Japan and China complete the global manufacturing network. All told, the Division currently employs more than 2,000 people with nearly 1,000,000 square feet of manufacturing space, all dedicated to quality, performance and timely response to your design and application needs.

Today, Eaton Corporation is one of the world's premier producers of electronic and electrical controls and vehicle components. With sales approaching \$7 billion annually, Eaton is ranked among the top 100 industrial companies in the United States, as well as one of the top 150 worldwide.

<http://www.eaton.com>



# ÒWÓ Series Motors

## Features

- ¥ Compact Size
- ¥ High Efficiency
- ¥ Tailored to Turf Care and Scissors Lift Markets
- ¥ Great Value

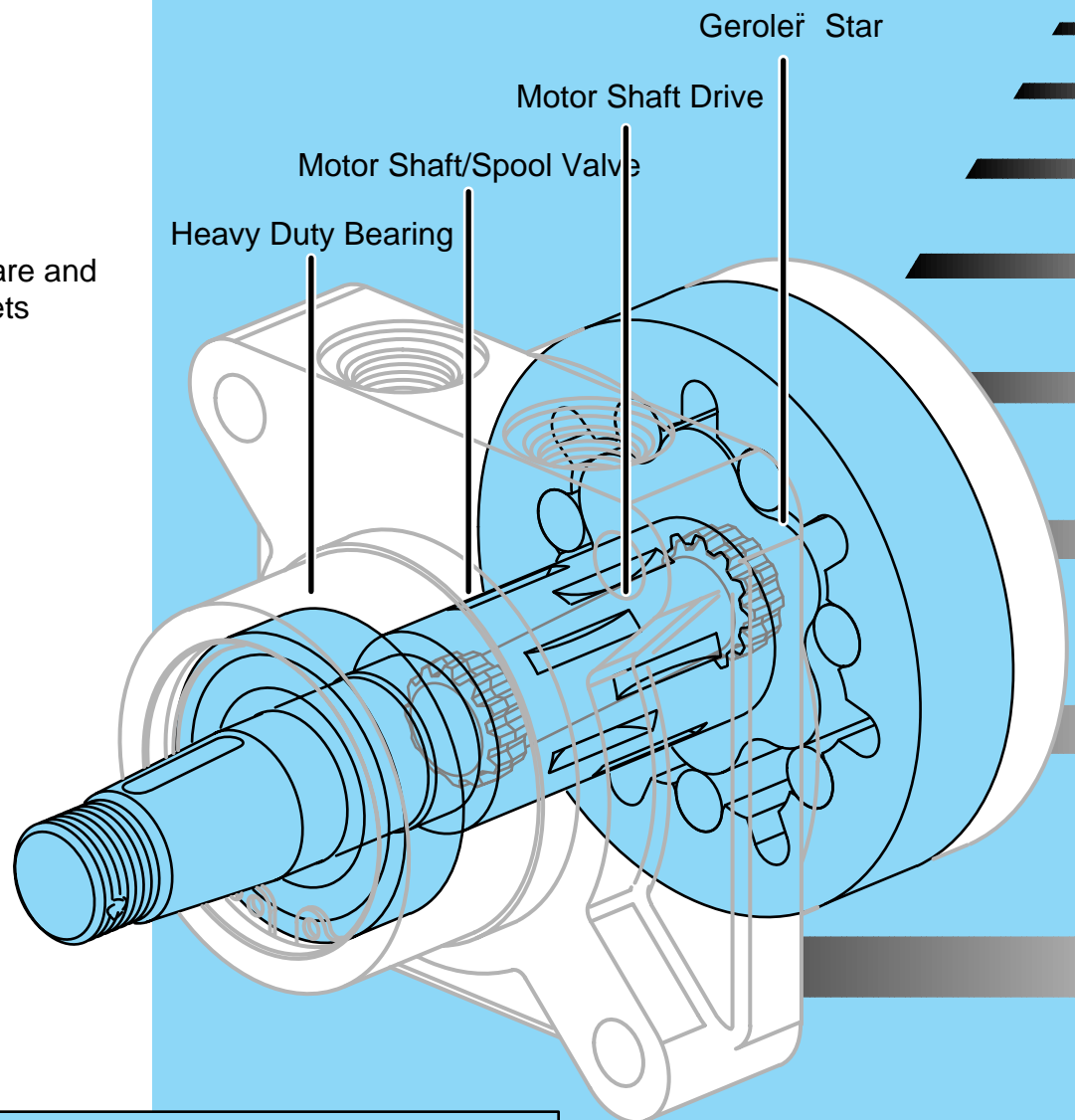

This catalog information was current at date of printing, but may be subject to change.



# Performance Data W Series

Motors run with high efficiency in all areas designated with a number for torque and speed. However, for best motor life, select a motor to run with a torque and speed range shown in the light blue area.

80 cm<sup>3</sup>/r [4.9 in<sup>3</sup>/r]  
D Pressure bar [PSI]

Continuous

	[400]	[600]	[800]	[1000]	[1200]	[1400]	[1600]	[1800]	[2000]	[2200]	[2400]	[2600]	
	28	41	55	69	83	97	110	124	138	152	165	179	
Flow l/min [GPM]	[2]	[204]	[337]	[474]	[612]	[748]	[883]	[1019]	[1149]	[1281]	[1412]	[1540]	[1610]
	7.6	23 93	38 89	54 88	69 84	85 83	100 79	115 73	130 69	145 69	160 61	174 56	182 39
	[4]	[223]	[357]	[489]	[627]	[769]	[902]	[1035]	[1169]	[1295]	[1424]	[1555]	[1676]
15.1	25 178	40 172	55 170	71 168	87 165	102 159	117 157	132 154	146 146	161 142	176 131	182 117	
[6]	[255]	[342]	[477]	[612]	[749]	[879]	[1014]	[1154]	[1286]	[1408]	[1533]	[1648]	
22.7	29 267	39 265	54 262	69 258	85 257	99 252	115 248	130 241	145 235	159 229	173 219	186 206	

126 cm<sup>3</sup>/r [7.7 in<sup>3</sup>/r]  
D Pressure bar [PSI]

Continuous

	[400]	[600]	[800]	[1000]	[1200]	[1400]	[1600]	[1800]	[2000]	[2200]	[2400]	[2600]	
	28	41	55	69	83	97	110	124	138	152	165	179	
Flow l/min [GPM]	[2]	[390]	[605]	[817]	[1032]	[1248]	[1448]	[1656]	[1871]	[2069]	[2243]	[2414]	[2513]
	7.6	44 58	68 56	92 55	117 51	141 49	164 45	187 43	211 41	234 33	253 32	273 26	284 17
	[4]	[382]	[605]	[817]	[1036]	[1252]	[1463]	[1694]	[1908]	[2113]	[2306]	[2470]	[2640]
15.1	43 113	68 106	92 106	117 104	141 93	165 97	191 94	216 88	239 82	261 79	279 74	298 60	
[6]	[367]	[587]	[802]	[1017]	[1236]	[1444]	[1668]	[1882]	[2091]	[2284]	[2459]	[2637]	
22.7	41 172	66 167	91 164	115 161	140 156	163 152	188 147	213 141	236 134	258 130	278 120	298 103	
[8]	[346]	[561]	[769]	[981]	[1203]	[1419]	[1634]	[1849]	[2039]	[2217]	[2432]	[2633]	
30.3	39 228	63 225	87 220	111 216	136 213	160 208	185 201	209 195	230 188	250 174	275 163	297 149	

154 cm<sup>3</sup>/r [9.4 in<sup>3</sup>/r]  
D Pressure bar [PSI]

Continuous

	[400]	[600]	[800]	[1000]	[1200]	[1400]	[1600]	[1800]	[2000]	[2200]	[2400]	[2600]	
	28	41	55	69	83	97	110	124	138	152	165	179	
Flow l/min [GPM]	[2]	[450]	[723]	[989]	[1249]	[1512]	[1769]	[2021]	[2269]	[2502]	[2714]	[2904]	[3019]
	7.6	51 47	82 47	112 46	141 44	171 40	200 39	228 36	256 33	283 30	307 26	328 19	341 10
	[4]	[470]	[737]	[1009]	[1276]	[1540]	[1802]	[2064]	[2323]	[2570]	[2813]	[3019]	[3242]
15.1	53 94	83 93	114 90	144 89	174 87	204 84	233 81	262 78	290 73	318 67	341 65	366 52	
[6]	[435]	[715]	[984]	[1252]	[1513]	[1787]	[2020]	[2274]	[2521]	[2812]	[3042]	[3301]	
22.7	49 143	81 140	111 138	141 137	171 134	202 131	228 128	257 124	285 117	318 112	344 103	373 91	
[8]	[407]	[677]	[945]	[1214]	[1477]	[1740]	[2005]	[2260]	[2503]	[2735]	[2964]	[3206]	
30.3	46 190	76 188	107 186	137 184	167 182	197 179	227 176	255 171	283 166	309 158	335 148	362 137	
[9]	[380]	[648]	[914]	[1183]	[1452]	[1714]	[1981]	[2243]	[2499]	[2733]	[2964]	[3195]	
34	43 214	73 212	103 210	134 207	164 206	194 202	224 200	253 196	282 191	309 182	335 173	361 162	

Continuous  
Intermittent

195 cm<sup>3</sup>/r [11.9 in<sup>3</sup>/r]  
D Pressure bar [PSI]

Continuous

	[400]	[600]	[800]	[1000]	[1200]	[1400]	[1600]	[1800]	[2000]	[2200]	[2400]	[2600]	
	28	41	55	69	83	97	110	124	138	152	165	179	
Flow l/min [GPM]	[2]	[478]	[827]	[1171]	[1511]	[1839]	[2153]	[2452]	[2756]	[3027]	[3275]	[3513]	[3673]
	7.6	54 38	93 38	132 37	171 36	208 35	243 34	277 34	311 30	342 29	370 26	397 22	415 16
	[4]	[515]	[872]	[1220]	[1558]	[1886]	[2206]	[2518]	[2816]	[3107]	[3382]	[3647]	[3882]
15.1	58 75	99 73	138 73	176 71	213 70	249 69	284 66	318 64	351 62	382 56	412 52	439 44	
[6]	[524]	[878]	[1214]	[1551]	[1875]	[2199]	[2518]	[2824]	[3113]	[3389]	[3666]		
22.7	59 114	99 111	137 111	175 110	212 108	248 106	284 105	319 103	352 99	383 95	414 91		
[8]	[518]	[856]	[1187]	[1524]	[1861]	[2187]	[2499]	[2782]	[3064]	[3334]			
30.3	59 151	97 150	134 150	172 149	210 147	247 145	282 144	314 143	346 141	377 136			
[10]	[462]	[797]	[1133]	[1468]	[1799]	[2118]	[2442]	[2739]	[3023]	[3281]			
38	52 190	90 188	128 187	166 186	203 184	239 184	276 182	309 179	342 176	371 160			

[3673] } Torque [lb-in]  
415 } Nm  
16 } Speed RPM

Performance data is typical at 120 SUS. Actual data may vary slightly from unit to unit in production.

# Performance Data W Series

251 cm<sup>3</sup>/r [15.3 in<sup>3</sup>/r]  
D Pressure bar [PSI]

		Continuous										
		[400]	[600]	[800]	[1000]	[1200]	[1400]	[1600]	[1800]	[2000]	[2200]	[2400]
		28	41	55	69	83	97	110	124	140	152	165
Flow l/min [GPM]	[2]	[759]	[1194]	[1683]	[2122]	[2535]	[2928]	[3319]	[3634]	[3946]	[4242]	[4553]
	7.6	86 30	135 29	190 29	240 28	286 27	331 27	375 25	411 22	446 17	479 15	514 14
	[4]	[806]	[1257]	[1691]	[2130]	[2563]	[2988]	[3381]	[3799]	[4147]	[4515]	[4849]
	15.1	91 59	142 58	191 58	241 56	290 55	338 55	382 52	429 48	469 47	510 41	548 40
	[6]	[780]	[1219]	[1646]	[2084]	[2515]	[2933]	[3336]	[3716]			
	22.7	88 90	138 88	186 87	235 86	284 85	331 83	377 83	420 79			
	[8]	[720]	[1148]	[1590]	[2029]	[2449]	[2861]	[3236]	[3627]			
30.3	81 120	130 118	180 117	229 117	277 114	323 112	366 111	410 108				
[10]	[645]	[1080]	[1513]	[1947]	[2371]	[2779]	[3151]	[3515]				
37.9	73 148	122 147	171 147	220 145	268 145	314 143	356 141	397 137				
[12]	[557]	[992]	[1428]	[1864]	[2292]	[2697]	[3087]					
45.4	63 178	112 177	161 176	211 174	259 174	305 172	349 169					
[14]	[460]	[888]	[1330]	[1761]	[2191]	[2615]	[3035]					
53.0	52 208	100 206	150 206	199 203	248 202	295 200	343 197					

Motors run with high efficiency in all areas designated with a number for torque and speed. However, for best motor life, select a motor to run with a torque and speed range shown in the light blue area.

303 cm<sup>3</sup>/r [18.5 in<sup>3</sup>/r]  
D Pressure bar [PSI]

		Continuous								
		[400]	[600]	[800]	[1000]	[1200]	[1400]	[1600]	[1800]	[2000]
		28	41	55	69	83	97	110	124	140
Flow l/min [GPM]	[2]	[920]	[1454]	[1974]	[2480]	[2969]	[3429]	[3859]	[4230]	[4583]
	7.6	104 24	164 24	223 24	280 23	335 22	387 22	436 20	478 18	518 16
	[4]	[960]	[1487]	[2007]	[2513]	[3006]	[3457]	[3905]	[4338]	[4769]
	15.1	108 49	168 49	227 47	284 47	340 46	391 45	441 44	490 41	539 39
	[6]	[911]	[1445]	[1961]	[2473]	[2952]	[3411]	[3842]	[4276]	
	22.7	103 73	163 73	222 72	279 72	334 71	385 69	434 68	483 66	
	[8]	[843]	[1375]	[1888]	[2393]	[2886]	[3350]	[3763]		
30.3	95 99	155 98	213 97	270 96	326 95	379 94	425 93			
[10]	[752]	[1274]	[1789]	[2303]	[2792]	[3274]	[3650]			
37.9	85 123	144 122	202 122	260 120	316 119	370 119	412 118			
[12]	[652]	[1170]	[1691]	[2199]	[2691]	[3123]				
45	74 148	132 147	191 146	248 145	304 145	353 144				
[14]	[526]	[1039]	[1560]	[2064]	[2548]	[2999]				
53	59 172	117 172	176 171	233 170	288 169	339 168				
[16.5]	[353]	[864]	[1367]	[1876]	[2369]					
62	40 203	98 203	154 201	212 200	268 200					

[4583]  
518 } Torque [lb-in]  
16 } Nm  
Speed RPM

Continuous  
Intermittent

374 cm<sup>3</sup>/r [22.8 in<sup>3</sup>/r]  
D Pressure bar [PSI]

		Continuous							
		[400]	[600]	[800]	[1000]	[1200]	[1400]	[1600]	[1800]
		28	41	55	69	83	97	110	124
Flow l/min [GPM]	[2]	[1086]	[1753]	[2365]	[2960]	[3533]	[4025]	[4484]	[4970]
	7.6	123 20	198 19	267 17	334 16	399 14	455 12	507 12	562 11
	[4]	[1152]	[1797]	[2431]	[3048]	[3624]	[4129]	[4599]	
	15.1	130 39	203 39	275 38	344 36	409 34	467 33	520 31	
	[6]	[1099]	[1749]	[2377]	[2996]	[3557]	[4077]		
	22.7	124 60	198 58	269 57	339 56	402 54	461 53		
	[8]	[1018]	[1662]	[2290]	[2894]	[3440]	[3952]		
30.3	115 80	188 79	259 78	327 76	389 75	447 74			
[10]	[940]	[1582]	[2210]	[2812]	[3346]	[3816]			
37.9	106 100	179 99	250 97	318 96	378 95	431 95			
[12]	[809]	[1454]	[2077]	[2677]	[3216]				
45.4	91 120	164 119	235 117	302 116	363 115				
[14]	[648]	[1284]	[1907]	[2506]	[3033]				
53.0	73 141	145 139	215 138	283 137	343 137				
[16]	[485]	[1107]	[1722]	[2315]	[2838]				
60.6	55 160	125 159	195 157	262 157	321 157				
[18]	[307]	[930]	[1543]	[2133]					
68.1	35 180	105 179	174 178	241 178					
[20]	[111]	[730]	[1342]	[1939]					
75.7	13 201	82 199	152 198	219 197					

Performance data is typical at 120 SUS. Actual data may vary slightly from unit to unit in production.

# Dimensions W Series

Displ. cm <sup>3</sup> /r [in <sup>3</sup> /r]	X Dim. Max.	Y Dim. Max.
80 [ 4.9]	9,1 [ .36]	116,6 [4.59]
126 [ 7.7]	11,9 [ .47]	119,6 [4.71]
154 [ 9.4]	14,7 [ .58]	122,2 [4.81]
195 [11.9]	18,5 [ .73]	126,2 [4.97]
251 [15.3]	23,9 [ .94]	131,6 [5.18]
303 [18.5]	29,0 [1.14]	136,4 [5.37]
374 [22.8]	35,6 [1.40]	143,3 [5.64]

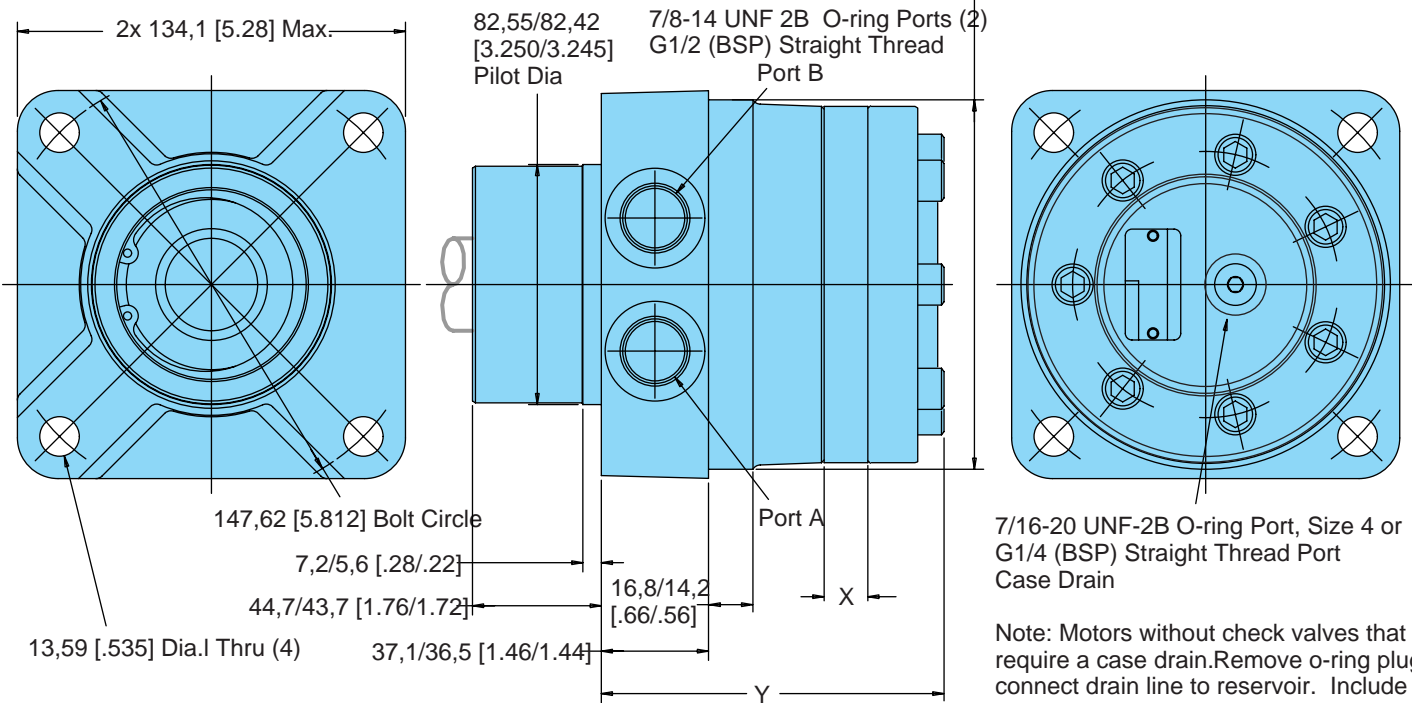
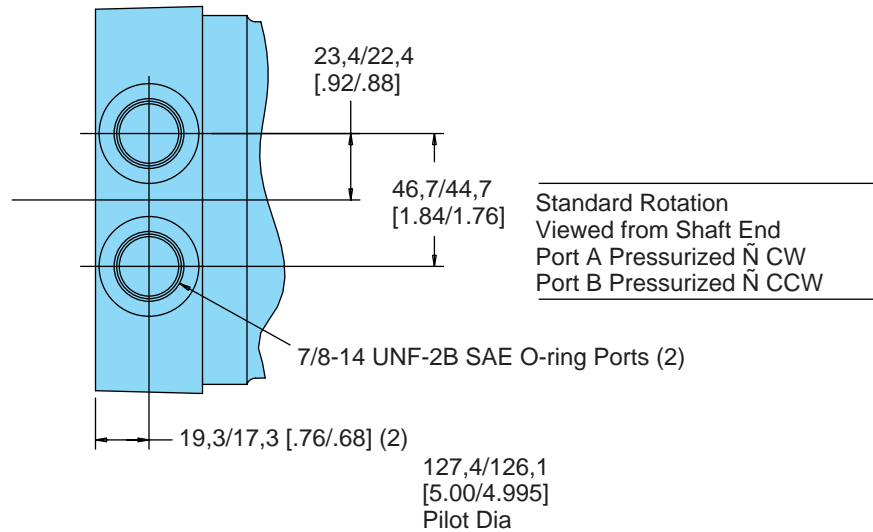

Note: Motors without check valves that require a case drain. Remove o-ring plug, connect drain line to reservoir. Include a relief valve (in the drain line) set to maintain 3,4 bar [50 PSI] motor case pressure.

Shaft Dimensions Ñ see page 8 and 9  
1-1/4 Inch Tapered  
1-1/4 Inch Straight  
32 mm Straight  
1-1/4 Inch 14 Tooth Splined

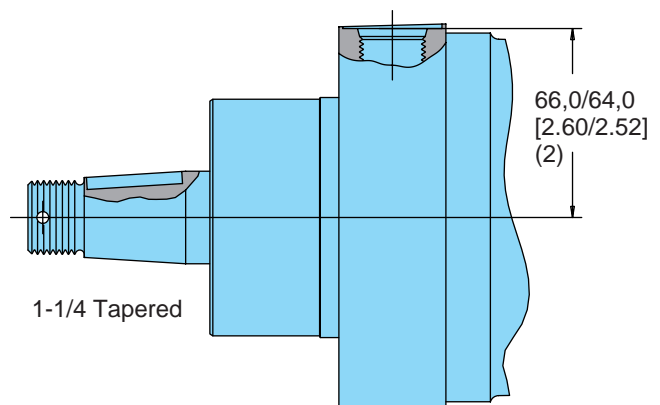

# Shaft Dimensions W Series

## 1-1/4 Tapered

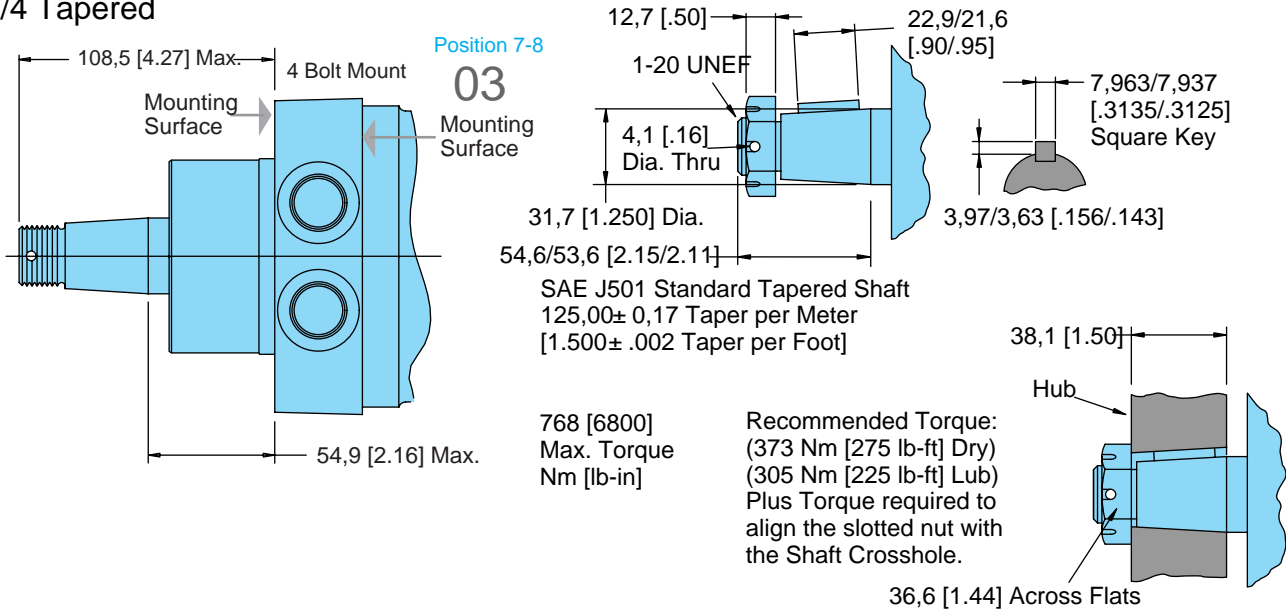

## 1-1/4 Inch Straight

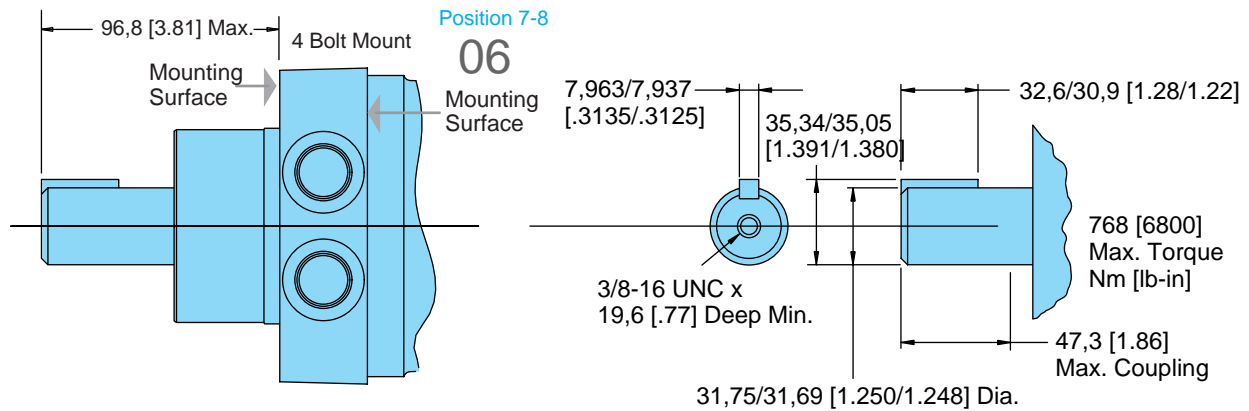

Shaft Information Continued

# Shaft Dimensions W Series

## 32 mm Straight

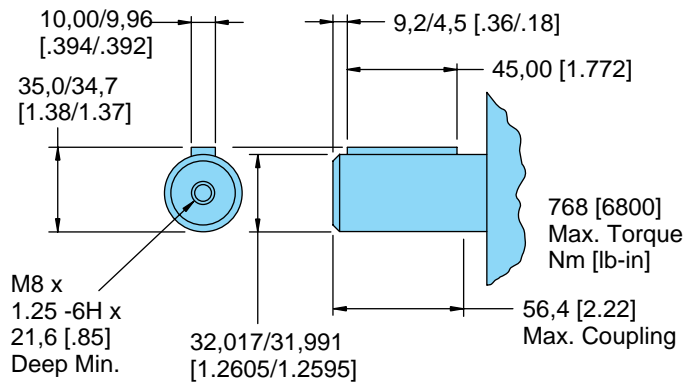
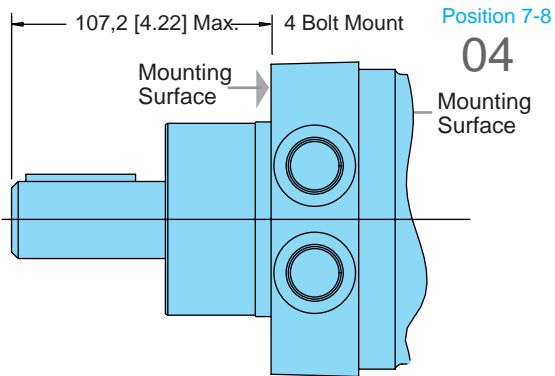

## 1-1/4 14 Tooth Splined

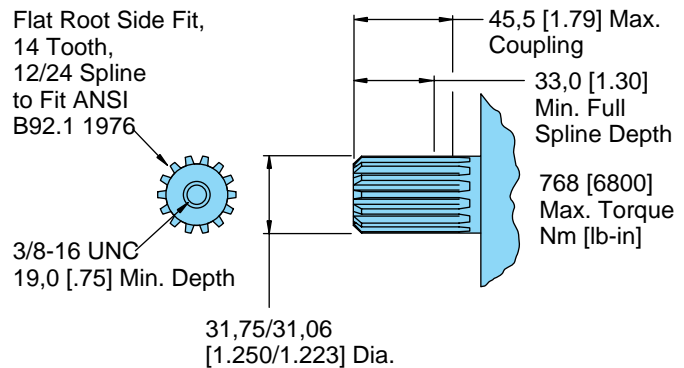
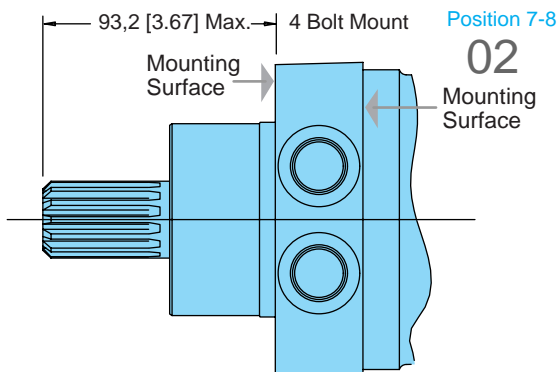

# Shaft Side Load Capacity W Series

Chart A  $\tilde{N}$  Expected B10 Life (hrs) of Bearing Under Various Loads

Axial Thrust N [lbf]	Radial Load at Centerline of keyway at 100 RPM									
	1110 [250]	2225 [500]	3335 [750]	4450 [1000]	4560 [1250]	6670 [1500]	7785 [1750]	8895 [2000]	11120 [2500]	13345 [3000]
445 [100]	410 600	66 000	19 600	8 300	4 200	2 400	1 500	1 000	530	310
1335 [300]	92 700	40 900	19 600	8 300	4 200	2 400	1 500	1 000	530	310
2225 [500]	39 400	20 900	12 400	7 900	4 200	2 400	1 500	1 000	530	310
3115 [700]	21 400	12 600	8 100	5 500	3 900	2 400	1 500	1 000	530	
4005 [900]	13 300	8 400	5 700	4 000	2 900	2 200	1 500	1 000	530	
4895 [1100]	9 000	6 000	4 200	3 100	2 300	1 800	1 400	1 000		
5785 [1300]	6 500	4 500	3 200	2 400	1 900	1 500	1 200	900		
6670 [1500]	4 800	3 500	2 600	2 000	1 500	1 200	1 000			
7560 [1700]	3 700	2 800	2 100	1 600	1 300					
8450 [1900]	3 000	2 200								

8895 [2000] Max. Thrust

- Note: 1) Case pressure needs to be added to the outward axial thrust load and subtracted from inward axial thrust load  $\tilde{N}$  Case Pressure bar x 87,1 [PSI x 1.35]
- 2) Life values in Chart A can be adjusted for speeds up to 200 rpm.  $\frac{\text{Life value} \times 100 \text{ rpm}}{\text{application rpm}}$
- 3) Shaded areas are intermittent loading.
- 4) To convert application radial load at any load location to side load at the center of keyway multiply load by the application factor from Chart B.

Chart B  $\tilde{N}$  Load Adjustment factor

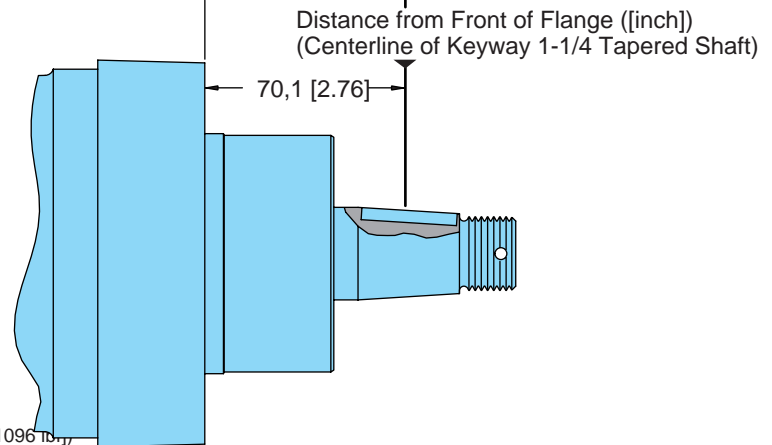
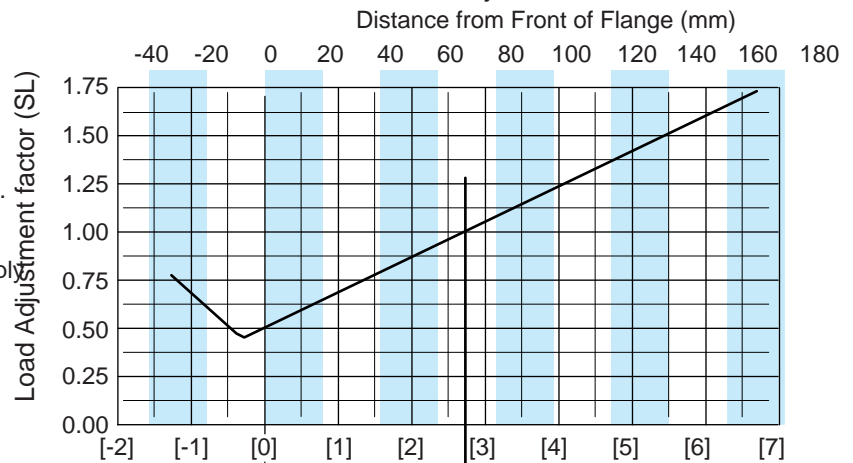

**Example:**

Side Load: 4849 N @ 120 mm [1090 lbf @ 4.75 inch] from flange.  
 Average Thrust Load: 890 N [200 lbf] inward (toward motor).  
 Case Pressure: 66 bar [960 PSI].  
 Average Speed: 150 rpm.

Expected Life Calculation:  
 Adjust side load value (due to load variation): Chart B  
 look at 120mm [4.75 inch] read at angled curve for load adjustment  
 factor of 1.38. Adjusted load is:  
 (4849 N [1090 lbf]) x (1.38) = 6690 N [1504 lbf]

Thrust Load Value (due to case pressure):

$$(960 \text{ PSI}) \times (1.35) = [1296 \text{ lbf}]$$

$$(66 \text{ bar}) \times (87,1) = 5750 \text{ N}$$

Average thrust load found to be 890 N [200 lbf] inwards so subtract from thrust load due from case pressure.

$$5750 \text{ N} - 890 \text{ N} = 4860 \text{ N} \quad \text{or} \quad [1296 \text{ lbf}] - 200 \text{ lbf} = [1096 \text{ lbf}]$$

Read Life Expectancy from Chart A: Value from chart reading across top to 6672 [1500] (6090 N [1504 lbf]) and down left side to 4895 [1100] (4875 N [1096 lbf])

Life = 1800 Hours

Speed Adjustment for over 100 rpm:

$$\frac{(1800 \text{ hrs}) \times (100 \text{ rpm})}{150 \text{ rpm}} = 1200 \text{ Hours}$$

## Case Drain W Series

### Parallel or Series Connection

Hydraulic lines bringing pressurized fluid from the pump to the motor and return flow from the motor back to tank can be flexible or rigid. One power source and one pump can be sized to supply one motor or many motors. Furthermore, one pump and multiple motors can be connected in series or in parallel (see illustration below). When connecting the pump to the motors in series, excess internal case pressure is created in the motor. This excess pressure in each motor must be ported back to tank. However, when making a parallel connection from the pump to the motors, no excess case pressure will be added. Hence, using the case drain ports are not necessary. Meanwhile, check the application to see if this optional case drain port can be connected to your advantage, whether it be a single motor to pump connection, multiple motors connected to pump in parallel, as well as multiple motors connected to pump in series...

...Case Drain Advantage Ñ In addition to providing lower case pressures for motors connected in series, there are advantages for adding an external case drain line to motors with normal case pressures as well. These advantages are: Contamination Control Ñ flushing the motor case. Cooler Systems Ñ exiting oil draws motor heat away. Extend Motor Seal Life Ñ maintain low case pressure with a preset restriction installed in the case drain line.

Motors ordered with case drain port will be shipped with steel hex socket plug installed in that end cap drain port.

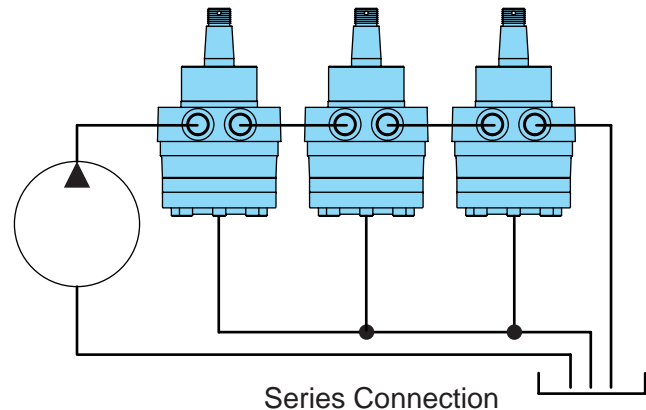
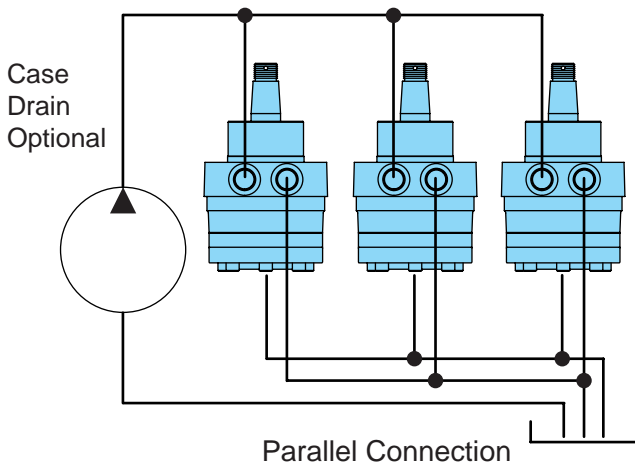

# Fluid Recommendations

## W Series

### Introduction

The ability of Eaton hydraulic components to provide the desired performance and life expectancy depends largely on the fluid used. The purpose of this section is to provide readers with the knowledge required to select the appropriate fluids for use in systems that employ Eaton hydraulic components.

One of the most important characteristics to consider when choosing a fluid to be used in a hydraulic system is viscosity. Viscosity choice is always a compromise; the fluid must be thin enough to flow easily but thick enough to seal and maintain a lubricating film between bearing and sealing surfaces. Viscosity requirements, see chart below.

### Viscosity and Temperature

Fluid temperature affects viscosity. In general, as the fluid warms it gets thinner and its viscosity decreases. The opposite is true when fluid cools. When choosing a fluid, it is important to consider the start-up and operating temperatures of the hydraulic system. Generally, the fluid is thick when the hydraulic system is started. With movement, the fluid warms to a point where a cooling system begins to operate.

From then on, the fluid is maintained at the temperature for which the hydraulic system was designed. In actual applications this sequence varies; hydraulic systems are used in many environments from very cold to very hot. Cooling systems also vary from very elaborate to very simple, so ambient temperature may affect operating temperature. Equipment manufacturers who use Eaton hydraulic components in their products should anticipate temperature in their designs and make the appropriate fluid recommendations to their customers.

### Cleanliness

Cleanliness of the fluid in a hydraulic system is extremely important. Eaton recommends that the fluid used in its hydraulic components be maintained at ISO Cleanliness Code 18/13 per SAE J1165. This code allows a maximum of 2500 particles per milliliter greater than 5 and a maximum of 80 particles per milliliter greater than 15. Cleanliness requirements for specific products are given in the table below.

OEMs and distributors who use Eaton hydraulic components in their products should provide for these requirements in their designs.

A reputable filter supplier can supply filter information.

### Fluid Maintenance

Maintaining correct fluid viscosity and cleanliness level is essential for all hydraulic systems. Since Eaton hydraulic components are used in a wide variety of applications it is impossible for Eaton to publish a fluid maintenance schedule that would cover every situation. Field testing and monitoring are the only ways to get accurate measurements of system cleanliness. OEMs and distributors who use Eaton hydraulic components should test and establish fluid maintenance schedules for their products. These maintenance schedules should be designed to meet the viscosity and cleanliness requirements laid out in this document.

### Fluid Selection

Premium grade petroleum based hydraulic fluids will provide the best performance in Eaton hydraulic components. These fluids typically contain additives that are beneficial to hydraulic systems. Eaton recommends fluids that contain anti-wear agents, rust inhibitors, anti-foaming agents, and oxidation inhibitors. Premium grade petroleum based hydraulic fluids carry an ISO VG rating.

SAE grade crankcase oils may be used in systems that employ Eaton hydraulic components, but it should be noted that these oils may not contain all of the recommended additives. This means using crankcase oils may increase fluid maintenance requirements.

Hydraulic fluids that contain V.I. (viscosity index) improvers, sometimes called multi-viscosity oils, may be used in systems that employ Eaton hydraulic components. These V.I. improved fluids are known to "shear-down" with use. This means that their actual viscosity drops below the rated value. Fluid maintenance must be increased if V.I. improved fluids are used. Automotive automatic transmission fluids contain V.I. improvers.

Synthetic fluids may be used in Eaton hydraulic components. A reputable fluid supplier can provide information on synthetic fluids. Review applications that require the use of synthetic fluids with your Eaton representative.

Product Line	Viscosity		ISO Cleanliness Requirements
	Minimum	Best Range	
W Series	70 SUS 13 cSt	100-200 SUS 20-43 cSt	18/13

### Additional Notes:

¥ Fluids too thick to flow in cold weather start-ups will cause pump cavitation and possible damage. Motor cavitation is not a problem during cold start-ups.

¥ When choosing a hydraulic fluid, all the components in the system must be considered and the best viscosity range adjusted accordingly. For example, when a medium duty piston pump is combined with a Geroler motor the best viscosity range becomes 100 - 150 SUS [20 - 32 cSt] and viscosity should never fall below 70 SUS [13 cSt].

¥ If the natural color of the fluid has become black it is possible that an overheating problem exists.

¥ If the fluid becomes milky a water contamination problem may exist.

¥ Take fluid level reading when the system is cold.

¥ Contact your Eaton representative if you have specific questions about the fluid requirements of Eaton hydraulic components.

## Product Numbers and Model Code for W Series Motors

Product Numbers W Series      Add three digit prefix 162 to four digit number from chart for complete product number. Example 162-1009.  
 Orders will not be accepted without three digit prefix.

Displ. cm <sup>3</sup> /r [in <sup>3</sup> /r]	80 [ 4.9]	126 [ 7.7]	154 [ 9.4]	195 [11.9]	251 [15.3]	303 [18.5]	374 [22.8]
Standard	162-1016	-1017	-1018	-1019	-1020	-1021	-1022
w/Case Drain	162-1023	-1024	-1025	-1009	-1008	-1026	-1027

Note: All above motors have 1-1/4 inch tapered output shaft, 7/8 inch o-ring ports.

162-1009

For W Series motors with a configuration not shown in the charts above: Use the model code number system to specify the product in detail.

# Model Code for W Series

The following 16-digit coding system has been developed to identify all of the configuration options for the W Series motor. All 16-digits of the code must be present when ordering. You may copy the matrix below to ensure that each number is entered in the correct box.

## Model Code for W Series Spool Valve Motors

1	2	3	4	5	6	7	8	9	10	11	12	13	14	15	16
M	0	W											3	0	0

**Position 1** Product Series

M ..... Motor

**Position 2, 3** W Series

OW ..... W Series

**Position 4, 5** Displacement  $cm^3/r$  [in<sup>3</sup>/r]

05 ..... 30 [ 4.9]

08 ..... 126 [ 7.7]

09 ..... 154 [ 9.4]

12 ..... 195 [11.9]

15 ..... 251 [15.3]

19 ..... 303 [18.5]

23 ..... 374 [22.8]

**Position 6** Mounting Flange

B ..... 4 Bolt (Wheel) 82,6 [3.25] Pilot Dia. and 13,59 [.535] Dia. Mounting Holes 147,6 [5.81] Dia., B.C., 127,0 [5.00] Dia. Rear Mount Pilot

**Position 7, 8** Output Shaft

02 ..... 1-1/4 inch Dia. Flat Root Side Fit, 14 Tooth, 12/24 DP 30° Involute Spline with 3/8-16 UNC-2B Thread in End, 33,0 [1.30] Min. Full Spline

03 ..... 1-1/4 inch Dia. .125:1 Tapered Shaft Per SAE J501 with 1Ø 20 UNEF -2A Threaded Shaft End and Slotted Hex Nut, 7,938 [.3125] Square x 22,22 [.875] Straight Key

04 ..... 32mm Dia. Straight Shaft with M8 x 1, 25-6H Thread in End, 9,982 [.3930] Wide x 7,995 [.3132] High x 45,00 [1.772] Long Key

06 ..... 1-1/4 inch Dia. Straight Shaft with 3/8 Ø 16 UNC 2B Thread in End, 7.938 [.3125] Square x 34,92 [1.375] Straight Key

**Position 9** Port Type

A ..... 7/8 Ø 14 UNF - 2B SAE O-ring Port

B ..... G 1/2 (BSP) Stright Thread Port

**Position 10** Case Flow Options

A ..... 7/16 - 20 UNF - 2B SAE O-ring Port

B ..... G 1/4 (BSP) Straight Thread Port

C ..... Internal Check Valve

**Position 11, 12** Special Features (Hardware)

00 ..... None

01 ..... Viton Seals

**Position 13** Special Features (Assembly)

0 ..... None

1 ..... Reverse Rotation

**Position 14** Paint/Special Packaging

0 ..... No Paint (Standard)

A ..... Painted Low Gloss Black

**Position 15** Eaton Assigned Code when Applicable

0 ..... Assigned Code

**Position 16** Eaton Assigned Design Code

0 ..... Assigned Design Code

# W Series



Eaton Corporation is a global manufacturer of highly engineered products that serve industrial, vehicle, construction, commercial and semiconductor markets. Principal products include electrical power distribution and control equipment, truck drivetrain systems, engine components, hydraulic products, ion implanters and a wide variety of controls. Headquartered in Cleveland, the company has 49,000 employees and 143 manufacturing sites in 26 countries around the world. Sales for 1997 were \$7.6 billion.

Information contained in this catalog is accurate as of the publication date and is subject to change without notice. Performance values are typical values. Customers are responsible for selecting products for their applications using normal engineering methods.

Eaton Corporation  
Hydraulics Division  
15151 Hwy. 5  
Eden Prairie, MN 55344  
Telephone: 612/937-7254  
Fax: 612/937-7130

Eaton Ltd.  
Hydraulics Division  
Glenrothes, Fife  
Scotland, KY7 4NW  
Telephone: [+44] (0)1592-771-771  
Fax: [+44] (0)1592-773-184

Eaton B.V.  
Boeing Avenue 11  
1119 PC Schiphol-Rijk  
The Netherlands  
Telephone: [+31] (0)20-655 6700  
Fax: [+31] (0)20-655 6800

Sumitomo Eaton Hydraulic Co.  
8 Temasek Blvd.  
42-01 Suntec Tower Three  
Singapore 03988  
Telephone: [+65] 832-7727  
Fax: [+65] 832-7733

Sumitomo Eaton  
Hydraulic Company Ltd.  
Ooi-Cho Kameoka-Shi  
621-0017 Kyoto  
Japan  
Telephone: [+81] 771-22-9601  
Fax: [+81] 771-29-2020

Eaton Ltd.  
7th Floor, Woo Duk Building  
832-2 Yeoksam-Dong, Kangnam-Ku  
Soeul 135-750  
Korea  
Telephone: [+82] 2-557-0595  
Fax: [+82] 2-557-1634

Eaton Hydraulics (Shanghai) Co. Ltd.  
388 Aidu Road, Waigaogiao FTZ  
Pudong New Area  
Shanghai 200137  
Peoples Republic of China  
Telephone: [+86] 21-5046 0758  
Fax: [+86] 21-5046 0767

Jining Eaton Hydraulic Co. Ltd.  
6 Ji Da Road  
Jining City  
Shandong Province 272131  
Peoples Republic of China  
Telephone: [+86] 537-2221288  
Fax: [+86] 537-2221557



Quality System Certified  
Products in this catalog are manufactured  
in an ISO-9001-certified site.