

Vickers®

# Servo Valves



## SX4 Servovalves

Flows to 76 l/min (20 USgpm) — Pressures to 350 bar (5000 psi)



# Introduction

Vickers SX4 servovalves provide closed loop control with exact positional accuracy, repeatable velocity profiles, and predictable force or torque regulation. Compared to Vickers SM4 servovalves, the SX4 offers extended frequency response and improved stability in closed loop systems.

Typical applications include plastic injection molding and blow molding systems, test and simulation equipment, die casting machines, hydraulic press brakes, animation and entertainment equipment, oil exploration vehicles, and lumber machinery.

The four models in the extended frequency response SX4 series offer a wide range of rated flows from 3,8 to 76 l/min (1.0 to 20 USgpm) at  $\Delta p$  of 70 bar (1000 psi).

The SX4 is a two-stage, modular design, flow control valve which can be manifold or subplate mounted. The symmetrical, dual coil, quad air gap torque motor mounts to the first stage nozzle flapper valve with six screws for better stability in high shock environments. An integral 35 micron absolute filter reduces sensitivity to contamination of the first stage. The second stage utilizes a four-way sliding spool and sleeve arrangement with a mechanical null adjust. Spool position is fed back to the first stage by means of a mechanical spring.

An SX4 servovalve can be used with a hydraulic cylinder, position transducer, and electronics for infinite cylinder position control to within 0,025 mm (0.001 in) or better, depending on component selection, length of stroke,

and load characteristics. When applied with servo hydraulic motors, tachometers, and electronics, the SX4 provides infinite proportional flow control for real-time velocity/acceleration profiles that can be closed loop error corrected to within one-tenth of a revolution per minute. With appropriate pressure transducers or load cells, cylinders, and electronics in force control applications, the SX4 offers exact load pressure/force control and excellent system stability with pressure to  $\pm 0,07$  bar ( $\pm 1$  psi) and load to  $\pm 1\%$  full scale.

The field-proven design of the SX4 servovalve, combined with Vickers precision manufacturing techniques, provides you with the optimum in system control.

## Features and Benefits

- The extended frequency response of the Vickers SX4 servovalve makes it the best competitive choice across a full range of applications.
- Each size of the extended frequency response SX4 is available in both standard response and high response models. The high response models offers enhanced system bandwidth for critical performance requirements.
- The wide range of SX4 flow capabilities allows selection of the valve size best suited for an application.
- The high strength aluminum alloy of the second stage valve body means lighter weight with rugged durability.
- The SX4-20 is also available with a special stainless steel body and end caps for operating pressures up to 350 bar (5000psi).
- The symmetrical, dual-coil, quad air gap, dry torque motor in Vickers servovalves, with its extremely fast response to input signals, results in highly accurate control profiles.
- The SX4's exclusive jeweled feedback ball receiver virtually eliminates the wear that can lead to loss of control across null in other servovalves.
- An improved null adjust provides smoother, more precise adjustment.
- Jeweled orifices greatly extend the life of the valve.
- An integral 35 micron filter provides extra first stage contamination protection.
- The spool and sleeve are hardened stainless steel to minimize wear and erosion. The sleeve is mounted with O-rings to eliminate spool binding and ensure smooth operation.
- Customized spool lap and sleeve porting are available to provide the specific flow control required for special applications.
- The SX4's symmetrical design provides inherently dependable metering of control flow and minimum null shifts. The result is more consistent machine operation.
- Viton\* seals are standard.
- The flexibility of standardized port circles, mounting patterns, and adapter manifolds makes Vickers servovalves a cost effective choice for replacing existing servovalves and enhancing existing systems.
- The SX4-20 is available with an optional pilot pressure port that allows either additional first stage filtration or the use of external pilot pressure for freedom from supply pressure fluctuations.
- The SX4 features a simple interface to an available dual filter module that provides extra protection against system contamination.

\* Viton is a registered trademark of the DuPont Co.

# Table of Contents

---

Operating Data .....	4
Performance Curves .....	8
Model Code .....	12
Installation Dimensions .....	13
SM4M(E) Mounting Subplates* .....	15
SM4A Adapter Manifolds* .....	20
SM4FV Flushing Valves* .....	26
SM4FM Filter Module* .....	28
Weights .....	30
Additional Accessories .....	30
Application Data .....	32

\* – For use with SX4 or SM4 valves

---

## Cross Section of Typical SX4-20 Servo Valve

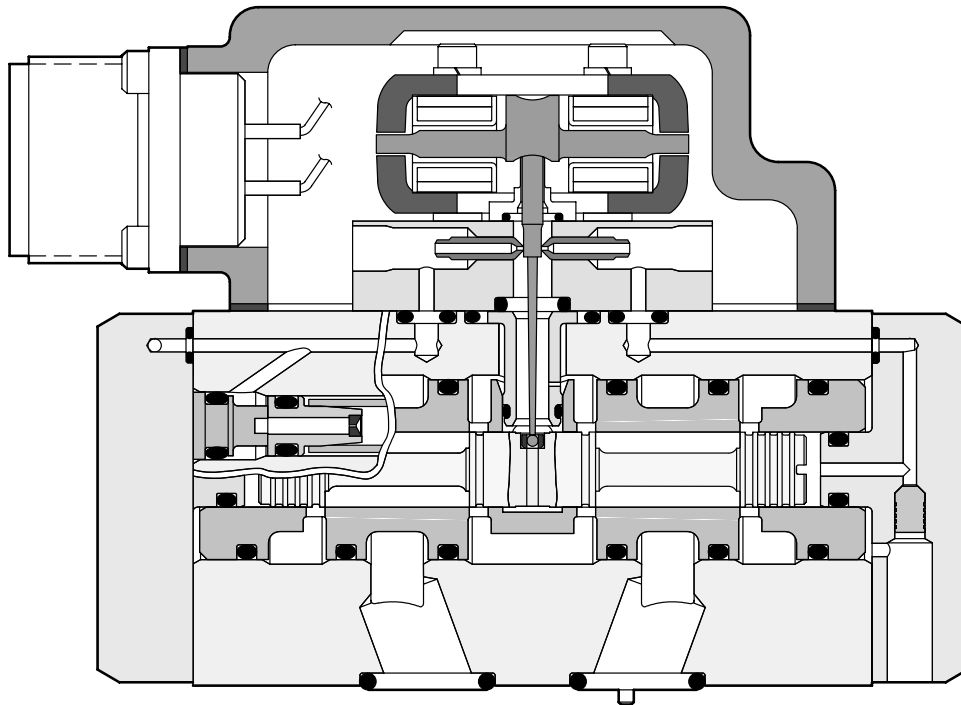

# Operating Data

## Flow and Leakage

All data is typical, based on actual tests at 70 bar (1000 psi)  $\Delta p$ , 30 cST (141 SUS), and 49°C (120°F).

Model Series	Maximum Rated Flow $\pm 10\%$ l/min (USgpm)	Maximum Total Null Leakage l/min (USgpm)	
		Standard Lap and Standard Response	Standard Lap and High Response
SX4-10	38 (10)	0,95 (0.25)	1,21 (0.32)
SX4-12	45 (12)	1,32 (0.35)	1,59 (0.42)
SX4-15	57 (15)	1,32 (0.35)	1,59 (0.42)
SX4-20	76 (20)	1,32 (0.35)	1,59 (0.42)
SX4-V-20	76 (20)	1,32 (0.35)	1,59 (0.42)

## Performance

<b>Maximum Supply Pressure</b> bar (psi)	SX4-10/12/15/20: 210 (3000) SX4-V-20: 350 (5000)
<b>Minimum Supply Pressure</b> bar (psi)	14 (200)
<b>Proof Pressure</b> % maximum supply pressure	At Supply Port: 150 At Return Port: 100
<b>Burst Pressure, Return Port Open</b> % maximum supply pressure	250
<b>Maximum Operating Temperature</b> °C (°F)	135 (275)
<b>Hysteresis Around Null</b> % of rated current	<3
<b>Symmetry Error</b> % of rated current	<10
<b>Linearity Error</b> % of rated current	<10
<b>Threshold</b> % of rated current	<0.5
<b>Maximum Pilot Flow at 70 bar (1000 psi) <math>\Delta p</math></b> l/min (USgpm)	Standard Response: 0,38 (0.1) High Response: 0,64 (0.17)

## Ruggedness Test Results

<b>Vibration Test</b> 5 Hz to 2000 Hz along each axis	No damage to components
<b>Shock Test</b> Up to 150g along all axes	No damage to components
<b>Endurance Test</b> To ISO 6404	No degradation in performance

# Operating Data

## Flow Gain

Normal region for standard models shown with typical no-load flow gain tolerances excluding hysteresis.

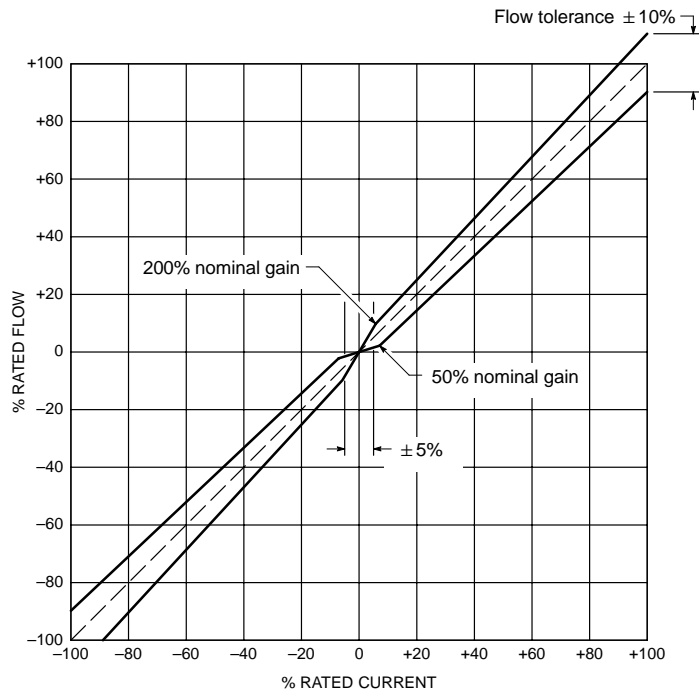

## Pressure Gain

The curve shows change in load pressure drop with input current, with no valve flow and closed control ports.

Pressure gain in the null region is  $>30\%$  of supply pressure per 1% of rated current.

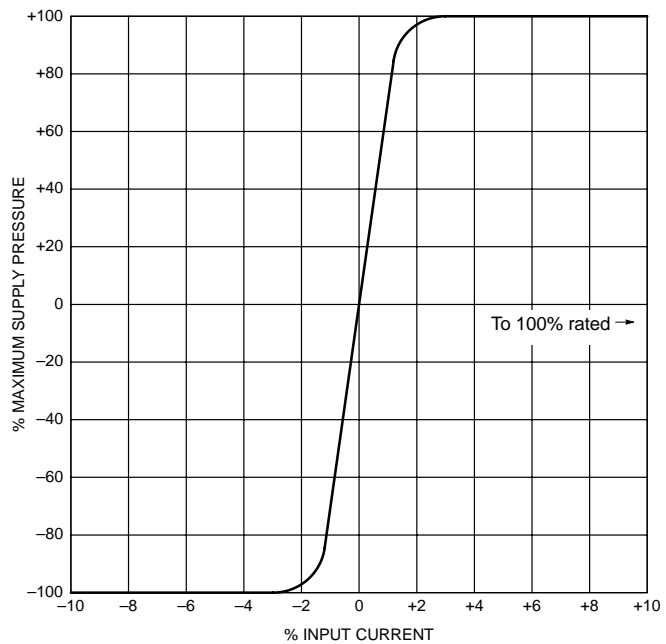

# Operating Data

## Change in Rated Flow vs. Pressure Drop

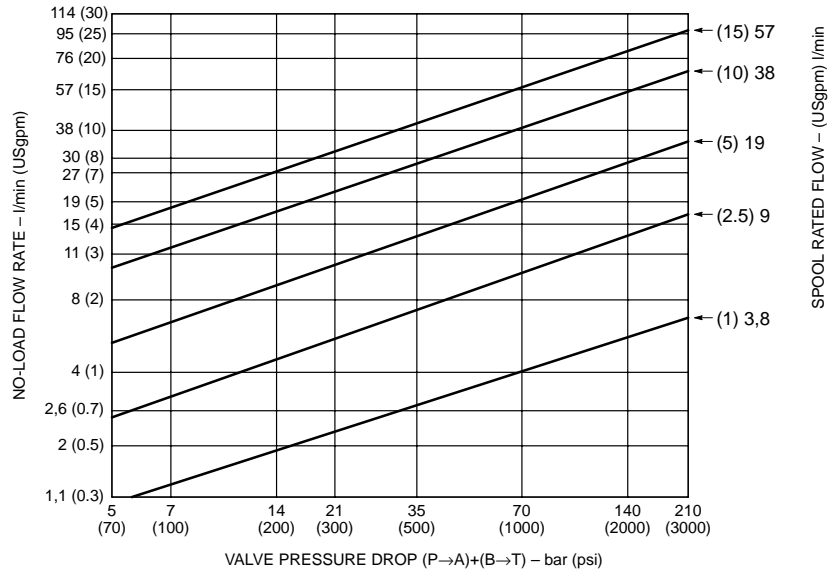

## Power Transmission Efficiency

The curve shows the maximum power envelope expressed as a percentage with T port pressure equal to 0 bar.

Power transferred to the load is optimum when valve pressure drop is one third of supply pressure. Load pressure drop should be limited to  $\frac{2}{3}$  of supply pressure so the flow gain of the servovalve remains high enough to maintain control of the load. Overall hydraulic efficiency must be considered when sizing system heat exchangers.

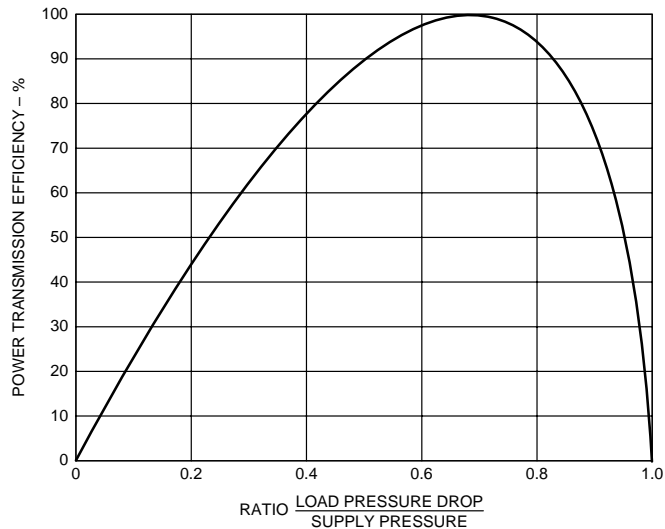

# Operating Data

## Coil Resistance

Select coil resistance and connections for compatible interface to servo electronics. **Recommended coil resistance is shown in bold print.**

	Nominal Resistance Per Coil at 21°C (70°F) Ohms	Rated Current mA	
		Single, Parallel, or Differential Connection	Series Connection
Standard response coil resistance selection	<b>20</b>	<b>200</b>	<b>100</b>
	30	100	50
	<b>80</b>	<b>40</b>	<b>20</b>
	80	50	25
	140	40	20
	200	15	7.5
	<b>200</b>	<b>20</b>	<b>10</b>
	300	30	15
	1000	10	5
	1500	8	4
High response coil resistance	<b>80</b>	<b>40</b>	<b>20</b>
	<b>200</b>	<b>20</b>	<b>10</b>

## Electrical Polarity for Control Flow Out of B Port

### Single:

A+, B-  
or  
C+, D-

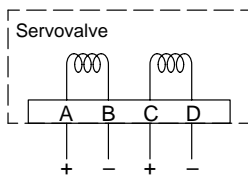

### Parallel:

A+, C+  
B-, D-  
Connect A and C  
Connect B and D

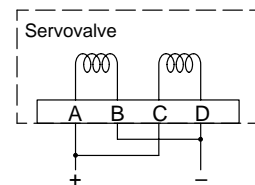

### Series:

A+, D-  
Connect B and C

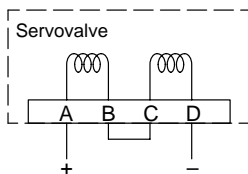

### Differential:

A-, D-  
B+, C+  
Connect B and C  
BC-, current BA>CD  
BC+, current CD>BA

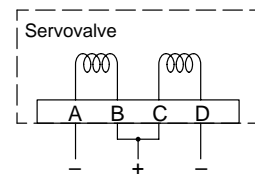

# Performance Curves

## Frequency Response

Frequency response is defined as the relationship of no-load control flow to input current with a sinusoidal current sweep at constant amplitude over a range of frequencies. It is expressed in frequency (Hz), amplitude ratio (dB), and phase angle (degrees).

As shown in the sample curve (below left), standard comparison points for servovalve frequency response are those frequencies at which  $-3$  dB ratio and  $90^\circ$  phase angle occur.

Vickers SX4 torque motors are magnetically stabilized for reliable servovalve performance at operating pressures from 14 to 350 bar (200 to 5000 psi).

## Calculating Frequency Response at System Pressure

$P_S$  = System pressure

$P_M$  = Maximum supply pressure of valve: 210 bar (3000 psi) for SX4-10/12/15/20 and 350 bar (5000 psi) for SX4-V-20

$f_{PM}$  = Frequency (at  $90^\circ$  phase angle) at maximum supply pressure ( $P_M$ )

$f_{PS}$  = Frequency (at  $90^\circ$  phase angle) at system pressure ( $P_S$ )

1. Calculate the ratio of system pressure to maximum supply pressure:

$$\frac{P_S}{P_M}$$

2. Use the result of step 1 and the curve below to estimate

$$\frac{f_{PS}}{f_{PM}}$$

3. Use the applicable frequency response curve from the following pages to estimate  $f_{PM}$  (the maximum supply pressure frequency response at  $90^\circ$  phase angle) for the desired valve.

4. Multiply the values obtained in steps 2 and 3. The result is  $f_{PS}$  (system pressure frequency response at  $90^\circ$  phase angle).

**Example:** A standard performance SX4-20 valve with a flow of 38 l/min (10 USgpm) is to be used at 165 bar (2400 psi).

1. Calculate the ratio of system pressure to maximum supply pressure:

$$\frac{P_S}{P_M} = \frac{2400 \text{ psi}}{3000 \text{ psi}} = 0.8$$

2. Use the result of step 1 and the curve below to estimate

$$\frac{f_{PS}}{f_{PM}} = 0.92$$

3. Use the frequency response curve from page 8 to estimate  $f_{PM}$ .

$$f_{PM} = 120 \text{ Hz}$$

4. Multiply the values obtained in steps 2 and 3. The result is  $f_{PS}$  (system pressure frequency response at  $90^\circ$  phase angle).

$$f_{PS} = 0.92 \times 120 \text{ Hz} = 110 \text{ Hz}$$

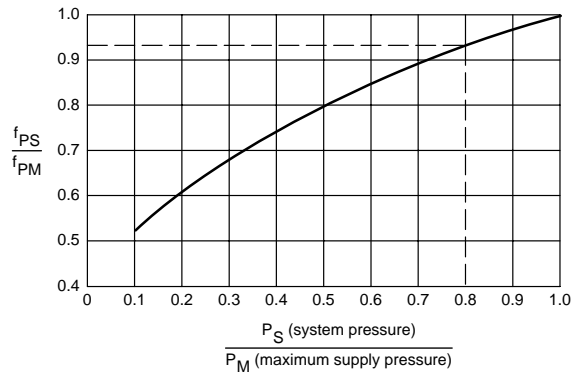
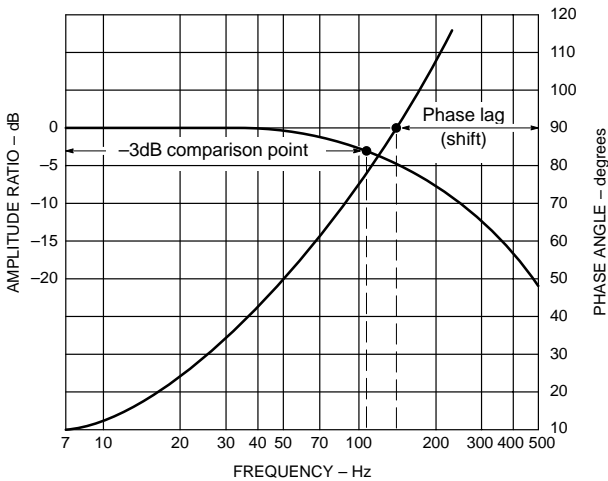

# Performance Curves

## Typical Frequency Response Curves

At 210 bar (3000 psi)

### 1, 2.5, and 5 USgpm servovalves

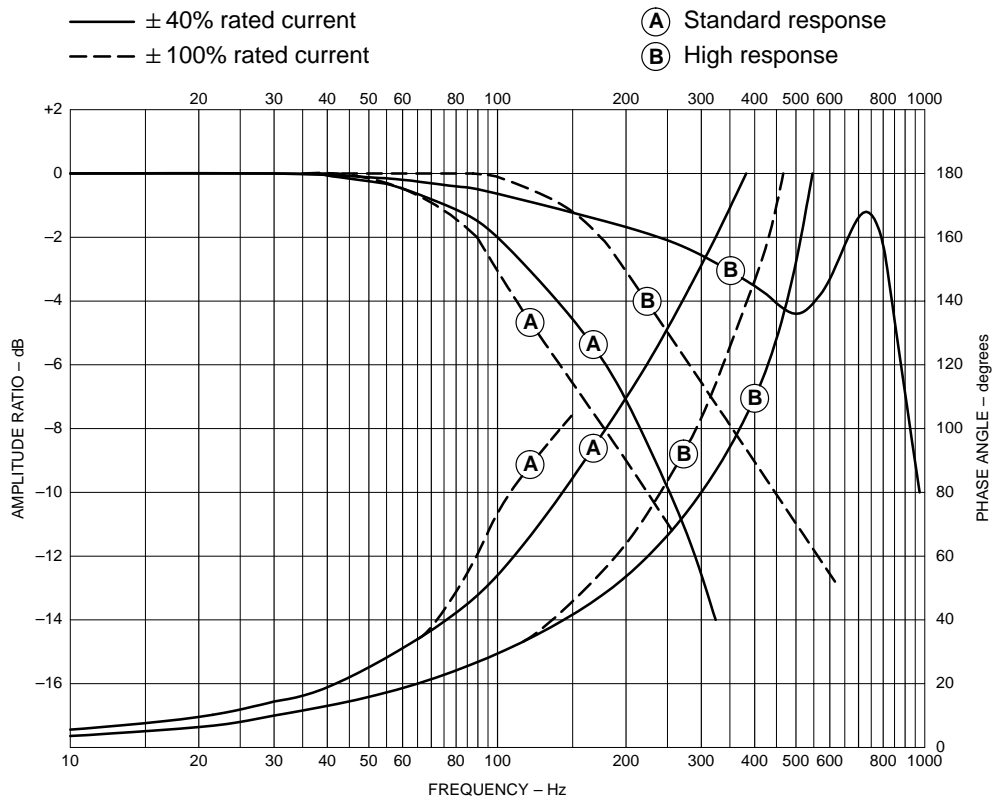

# Performance Curves

## 10 USgpm servovalves

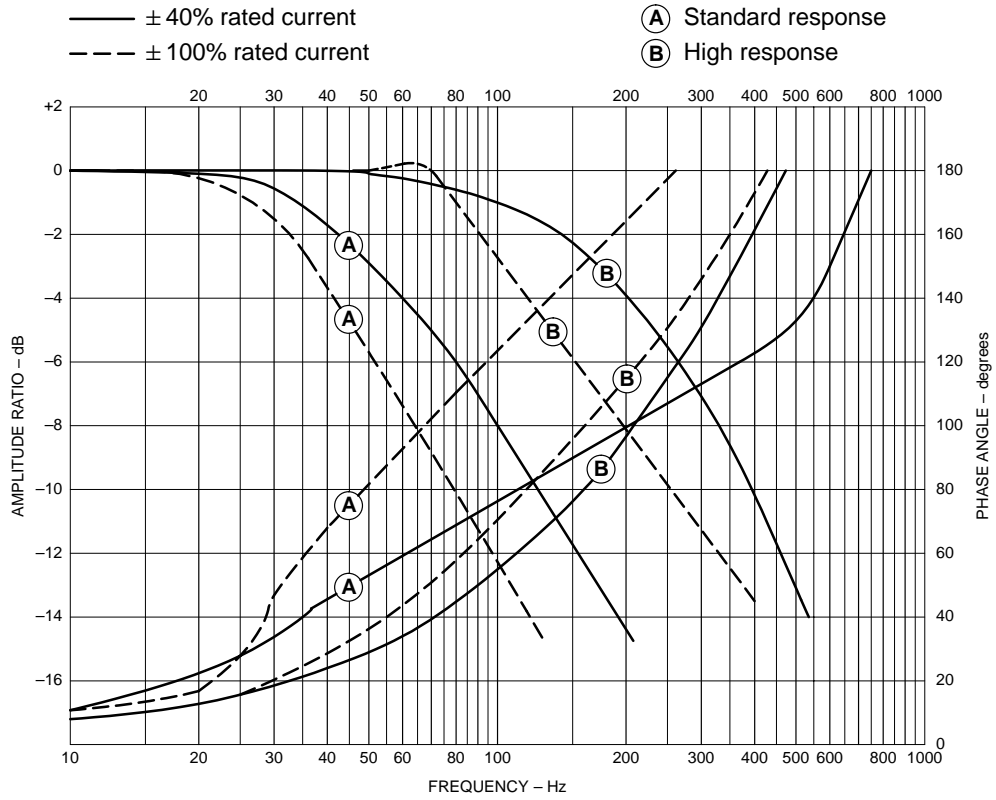

## 15 and 20 USgpm servovalves

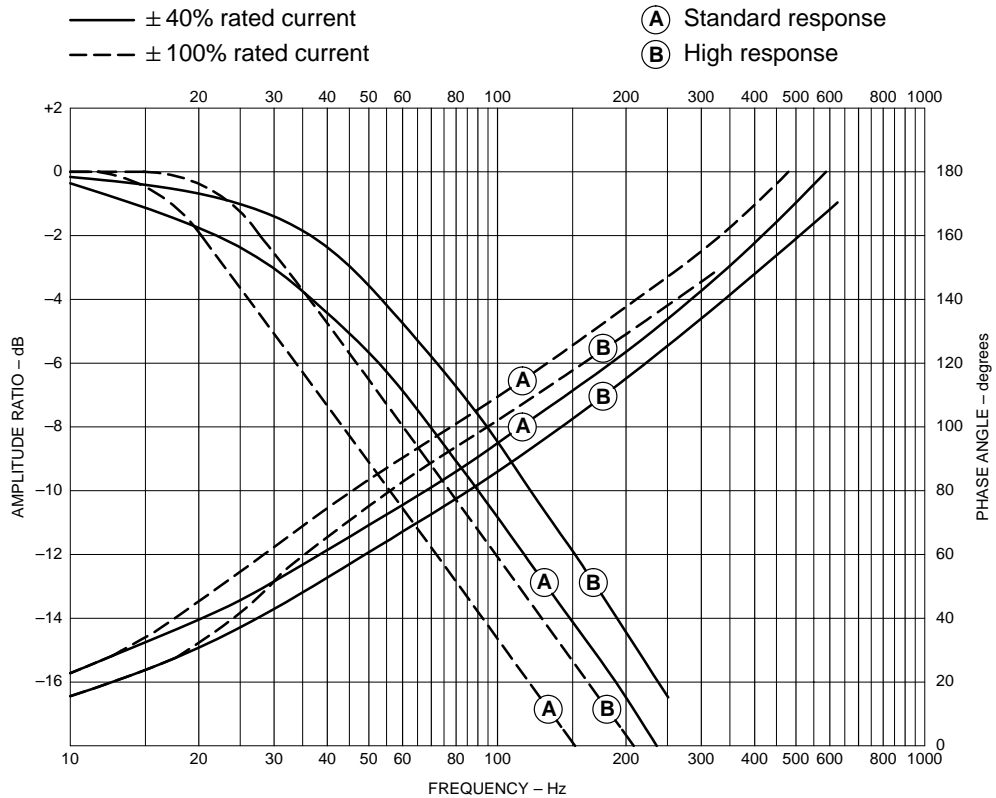

# Performance Curves

## Step Response

Step response is defined as the typical rise time needed to achieve a given percentage of control flow output. Settling time is the time needed for transient flow fluctuations to diminish to within a given accuracy range. Both are expressed in milliseconds (ms).

The example at right shows the step response curves for a critically damped valve and an underdamped valve. Rise times are illustrated for 63% of control flow output, and settling times are shown at 95% of control flow output.

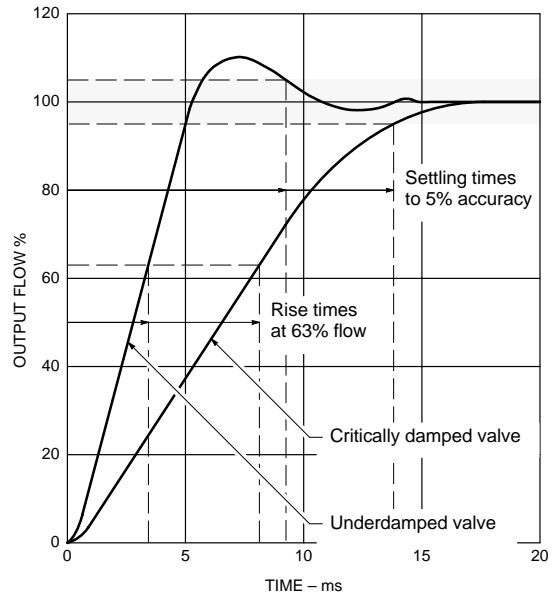

## Typical Step Response Curves for Standard Models

SX4-10/12/15/20 shown at 210 bar (3000 psi).

- ① 1, 2.5, and 5 USgpm high response
- ④ 10 USgpm standard response
- ② 1, 2.5, and 5 USgpm standard response
- ⑤ 15 and 20 USgpm high response
- ③ 10 USgpm high response
- ⑥ 15 and 20 USgpm standard response

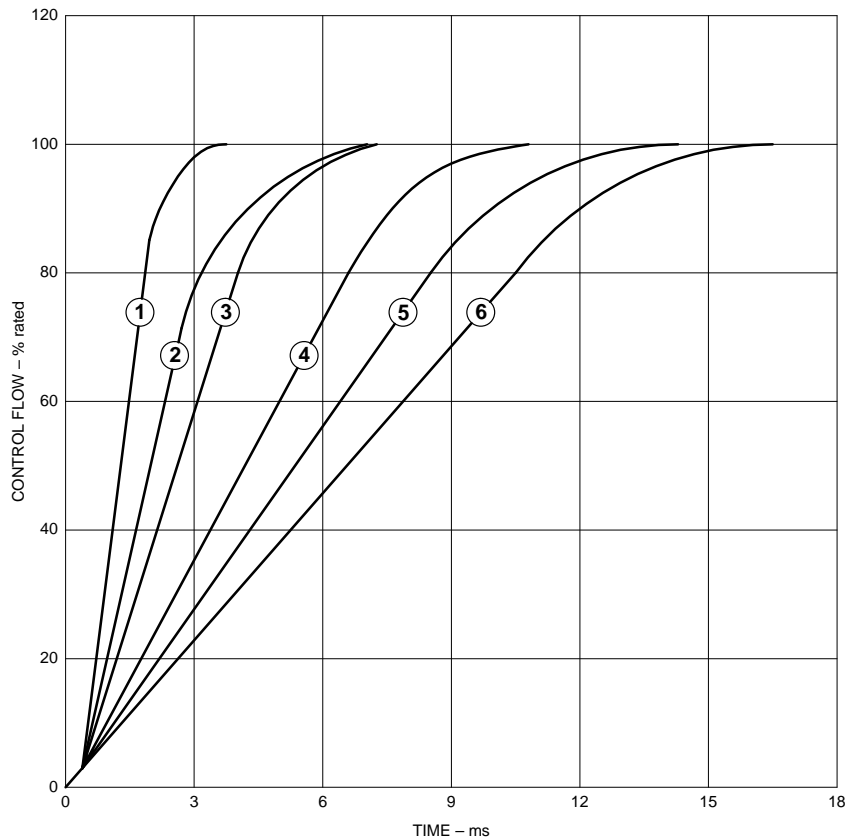

# Model Code

**SX4 - (H) (V) - \*\* (\*\*) \*\* - \*\*\*/\*\* - 10 - (S \*\*\*)**

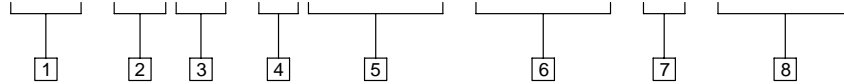

## 1 Series designation

SX4 – Servovalve, extended frequency response, four-way

## 2 Response

Blank – Standard response  
H – High response\*

\* – High response at flow rates above 38 l/min (10 USgpm) available in SX4-20 valve size only.

## 3 Pressure rating

Blank – 210 bar (3000 psi)  
V – 350 bar (5000 psi)

## 4 Valve size (mechanical interface)

10 – 15,9 mm (0.625 in) port circle  
12 – 19,8 mm (0.780 in) port circle  
15 – 23,8 mm (0.937 in) port circle  
20 – 22,2 mm (0.875 in) port circle

## 5 Flow rating

At 70 bar (1000 psi)  $\Delta p$  P→A→B→T.  
Other flows available on request.

Code	USgpm	l/min
(1) 3,8	1.0	3,8
(2.5) 9	2.5	9
(5) 19	5.0	19
(10) 38	10.0	38
(15) 57**	15.0	57
(20) 76†	20.0	76

\*\* – 15 and 20 size valves only  
† – 20 size valves only

## 6 Coil resistance/rated current

Ohms/mA at 21°C (70°F). Other coils available on request.

Code	Ohms	mA
20/200	20	200
30/100	30	100
80/40	80	40
80/50	80	50
140/40	140	40
200/15	200	15
200/20	200	20
300/30	300	30
1000/10	1000	10
1500/8	1500	8

## 7 Design number

Subject to change. Installation dimensions same for designs 10 through 19.

## 8 Special feature suffix

S\*\*\* – Vickers assigns a unique suffix to denote a particular group of special features. Contact your Vickers representative for details.

Blank – Standard valve

# Installation Dimensions

## SX4-10/12/15

millimeters (inches)

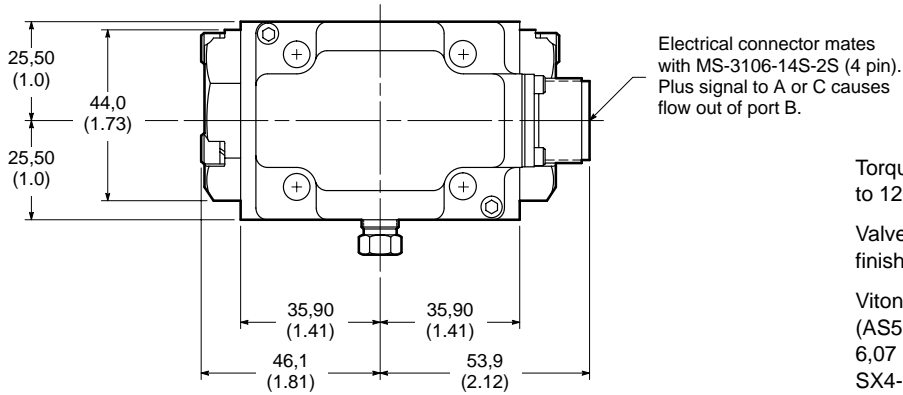

### NOTES

Torque mounting screws to 12 to 14 Nm (108 to 120 lb.in.).

Valve mounting surface requires 32 microinch finish flat within 0,025 (0.001).

Viton port O-rings provided. SX4-10 O-rings (AS568-010): 1,78 (0.070) cross section and 6,07 (0.239) inner diameter. SX4-12 and SX4-15 O-rings (AS568-013): 1,78 (0.070) cross section and 10,82 (0.426) inner diameter.

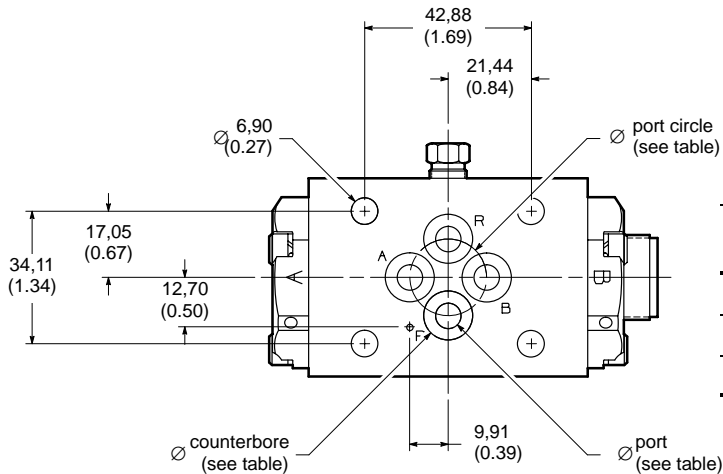
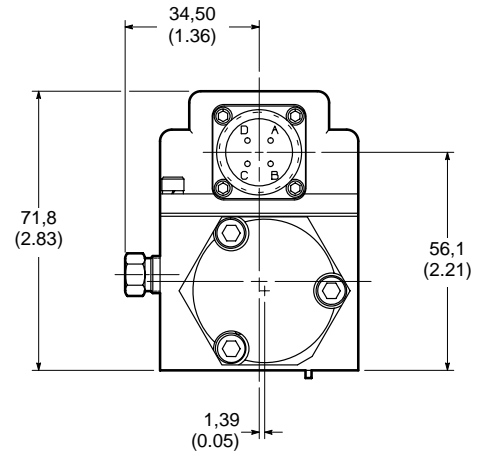
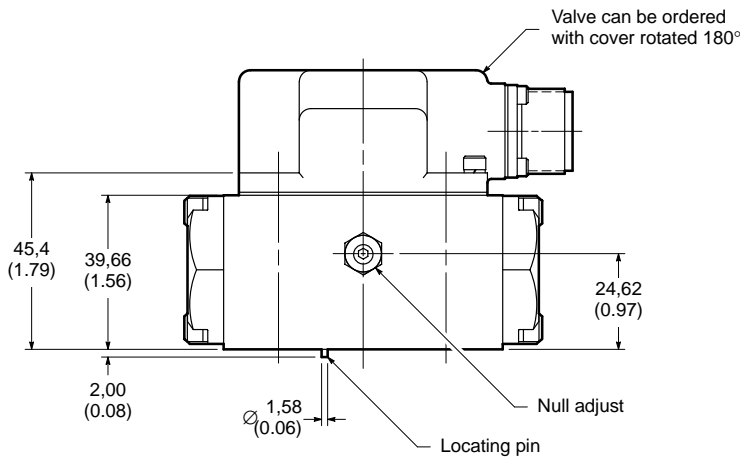

Valve Size	Port Circle Diameter	Port Diameter	Counterbore Diameter
10	15,88 (0.625)	4,85 (0.191)	9,58 (0.377)
12	19,80 (0.780)	6,60 (0.260)	12,74 (0.501)
15	23,80 (0.937)	7,92 (0.312)	14,30 (0.563)

# Installation Dimensions

## SX4-20

millimeters (inches)

Electrical connector mates with MS-3106-14S-2S (4 pin). Plus signal to A or C causes flow out of port B.

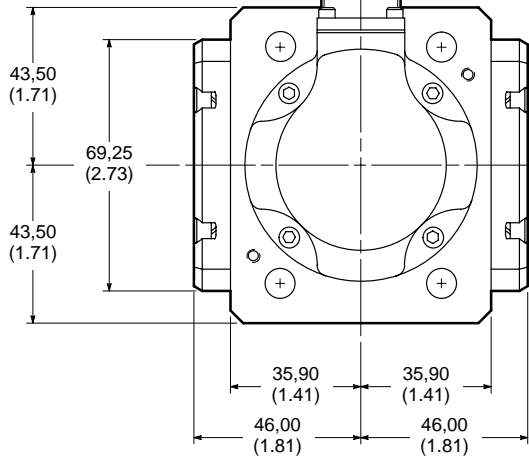

### NOTES

Torque mounting screws to 14 to 15 Nm (120 to 130 lb.in.).

Valve mounting surface requires 32 microinch finish flat within 0,025 (0.001).

Viton port O-rings provided. SX4-20 O-rings (AS568-013): 1,78 (0.070) cross section and 10,82 (0.426) inner diameter.

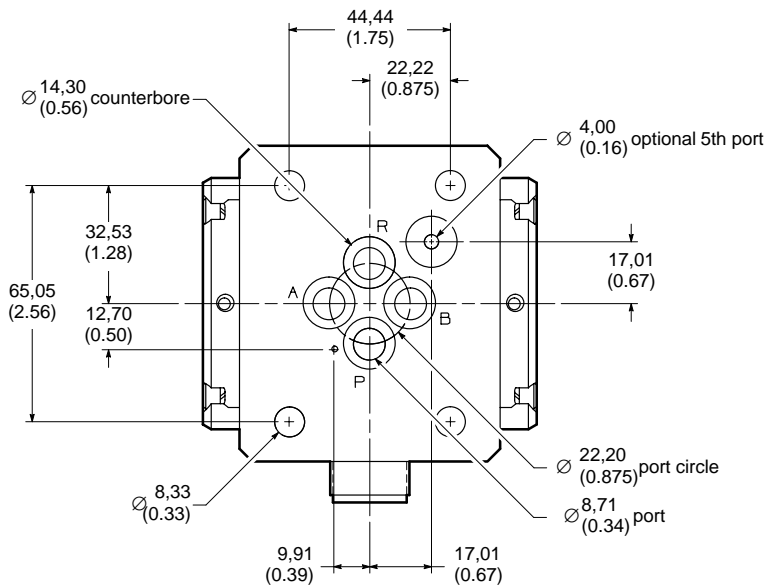
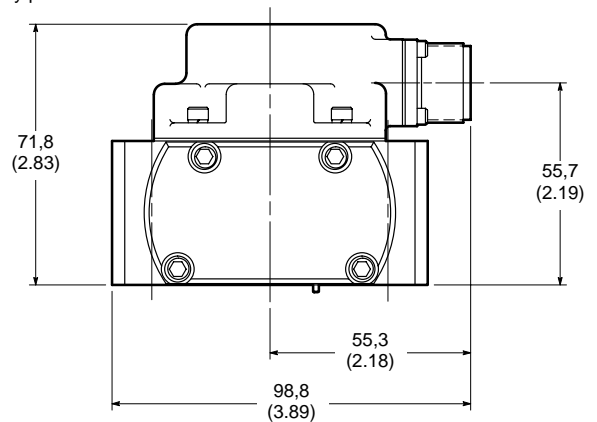
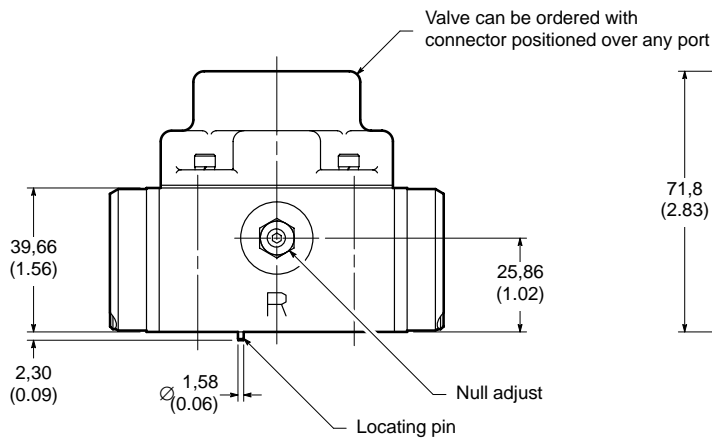

# SM4M(E) Mounting Subplates

## Model Code

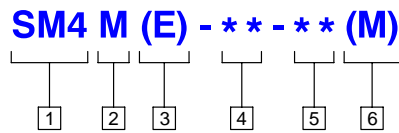

### 1 Series designation

SM4 – Servovalve, high performance, four-way (for use with SX4 or SM4 valves)

### 2 Accessory designation

M – Mounting subplate. Maximum supply pressure of 210 bar (3000 psi), except -5\* designs of SM4M(E)-20 with maximum supply pressure of 350 bar (5000 psi).

### 3 Port connection locations

Blank – Rear ports  
E – Side ports

### 4 Standard SM4 valve size

10 – SM4-10  
12 – SM4-12  
15 – SM4-15  
20 – SM4-20 or SP4-25

### 5 Design number

Subject to change.

SM4M(E)-10/12/15/20 installation dimensions same for designs 10 through 19.

SM4M(E)-20 installation dimensions same for designs 50 through 59. Maximum supply pressure of 350 bar (5000 psi).

### 6 Metric suffix

M – Metric version to NG (ISO) standards  
Blank – Omit if not required

# SM4M(E) Mounting Subplates

## Installation Dimensions

millimeters (inches)

**SM4M-10-10,  
SM4M-12-10,  
and SM4M-15-10**

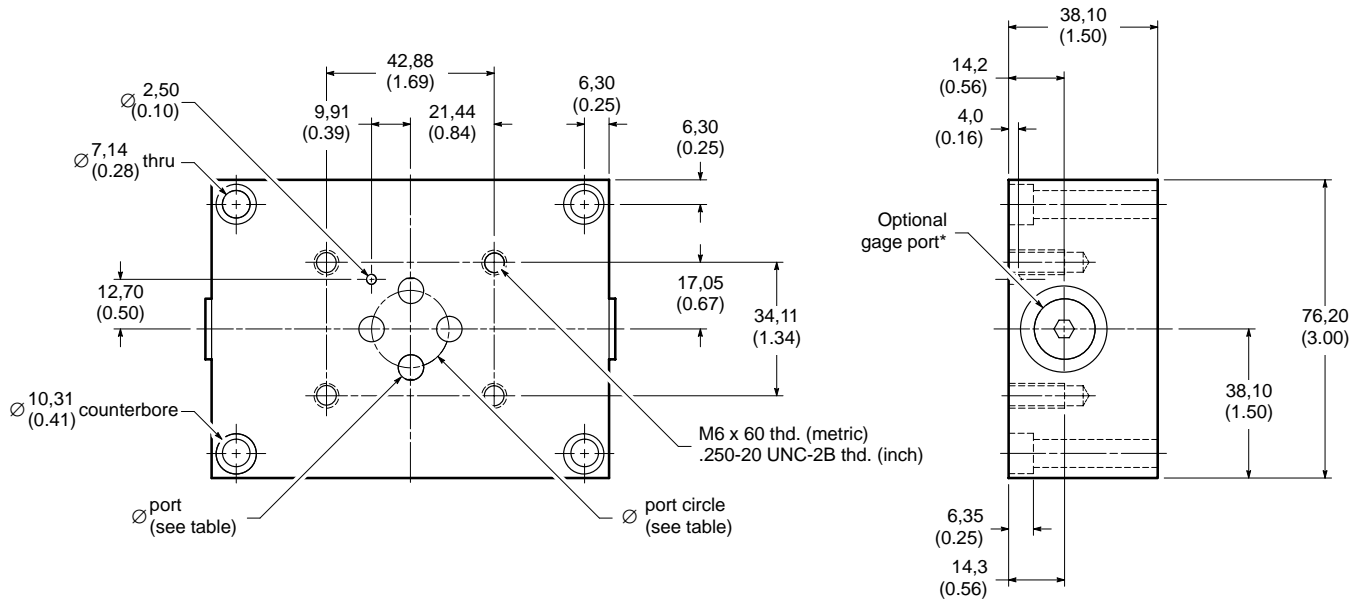

\* - 6,35 (0.25) O.D. tube  
G<sup>1</sup>/<sub>4</sub> (metric)  
.4375-20 UNF-2B thd. (inch)

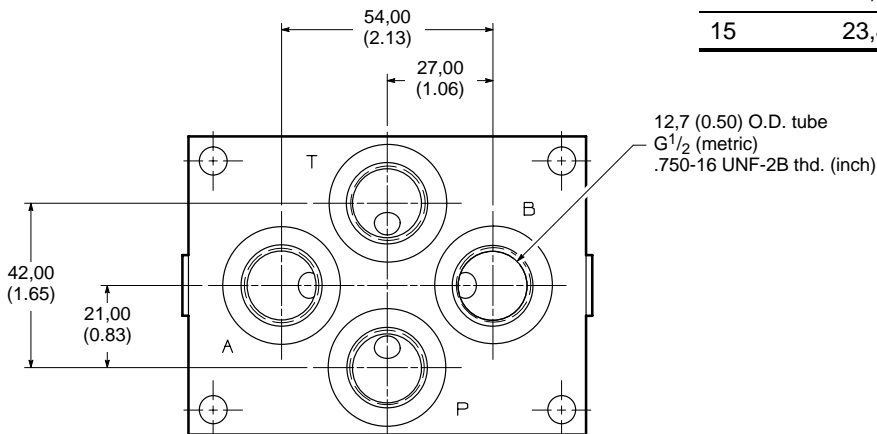

Subplate Size	Port Circle Diameter	Port Diameter
10	15,88 (0.625)	4,85 (0.191)
12	19,80 (0.780)	6,60 (0.260)
15	23,80 (0.937)	7,92 (0.312)

# SM4M(E) Mounting Subplates

**SM4ME-10-10,  
SM4ME-12-10,  
and SM4ME-15-10**

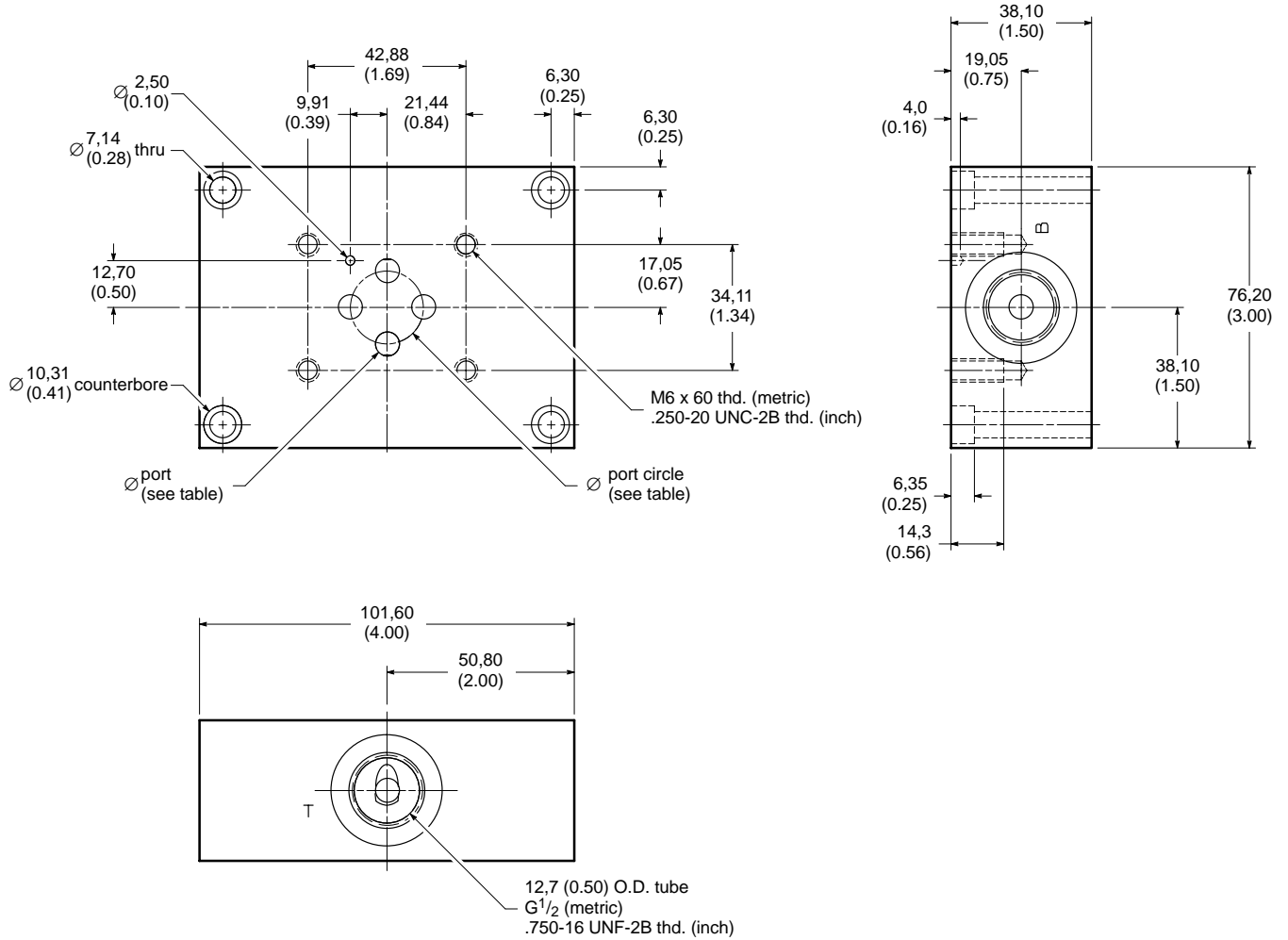

Subplate Size	Port Circle Diameter	Port Diameter
10	15,88 (0.625)	4,85 (0.191)
12	19,80 (0.780)	6,60 (0.260)
15	23,80 (0.937)	7,92 (0.312)

# SM4M(E) Mounting Subplates

## SM4M-20-10/50

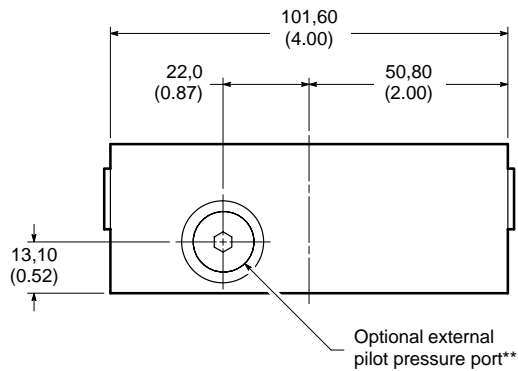
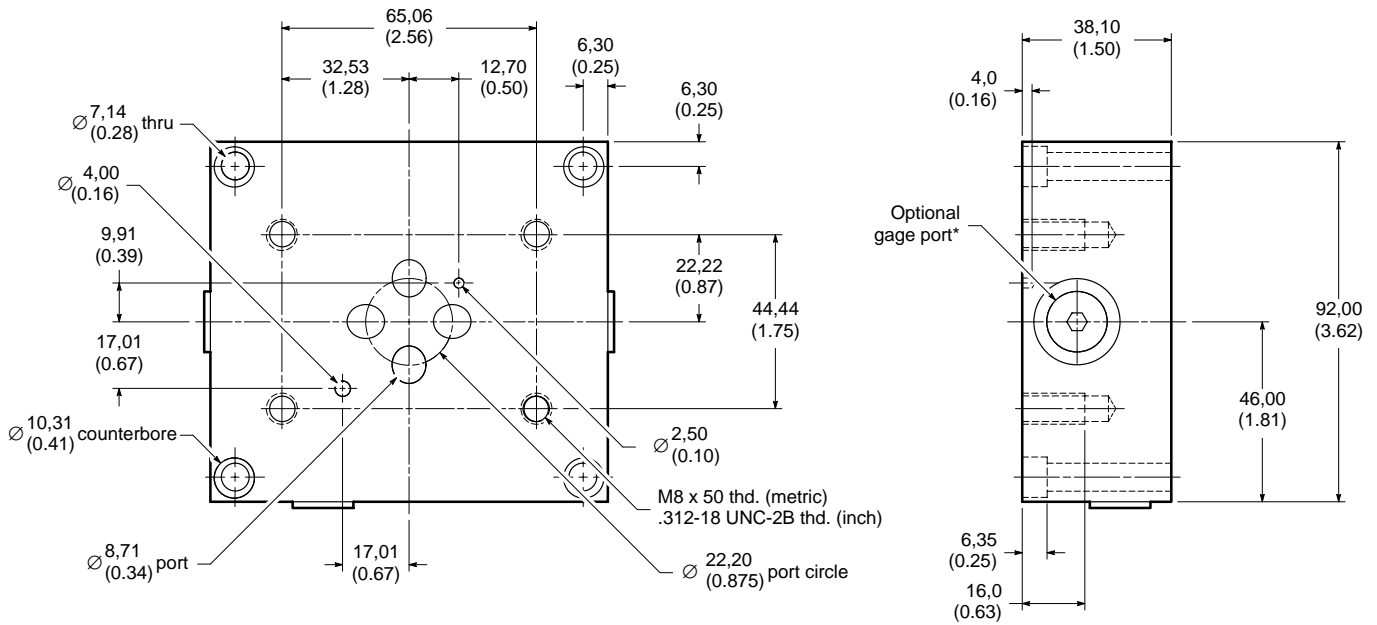

- \* - SM4M-20-10 only  
6.35 (0.25) O.D. tube  
G<sup>1</sup>/<sub>4</sub> (metric)  
.4375-20 UNF-2B thd. (inch)
- \*\* - 6.35 (0.25) O.D. tube  
G<sup>1</sup>/<sub>4</sub> (metric)  
.4375-20 UNF-2B thd. (inch)

## SM4M-20-10

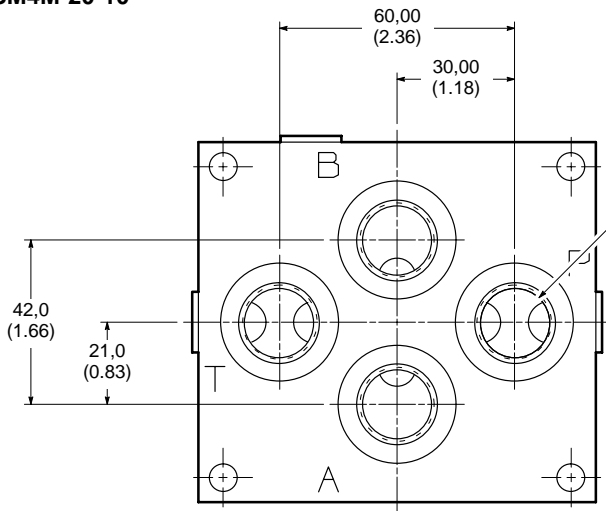

## SM4M-20-50

(All other dimensions same as SM4M-20-10)

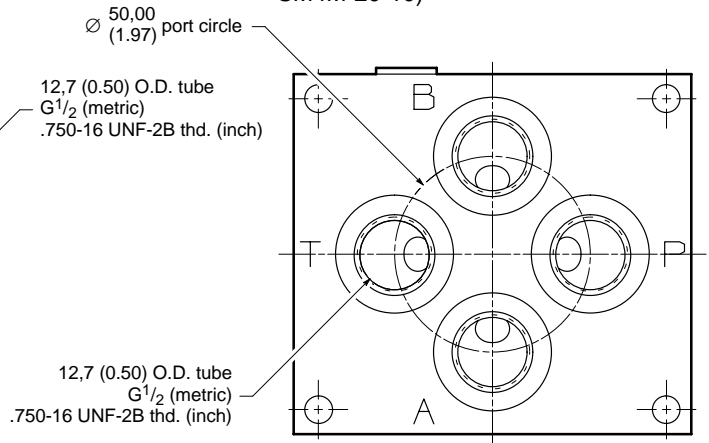

# SM4M(E) Mounting Subplates

## SM4ME-20-10/50

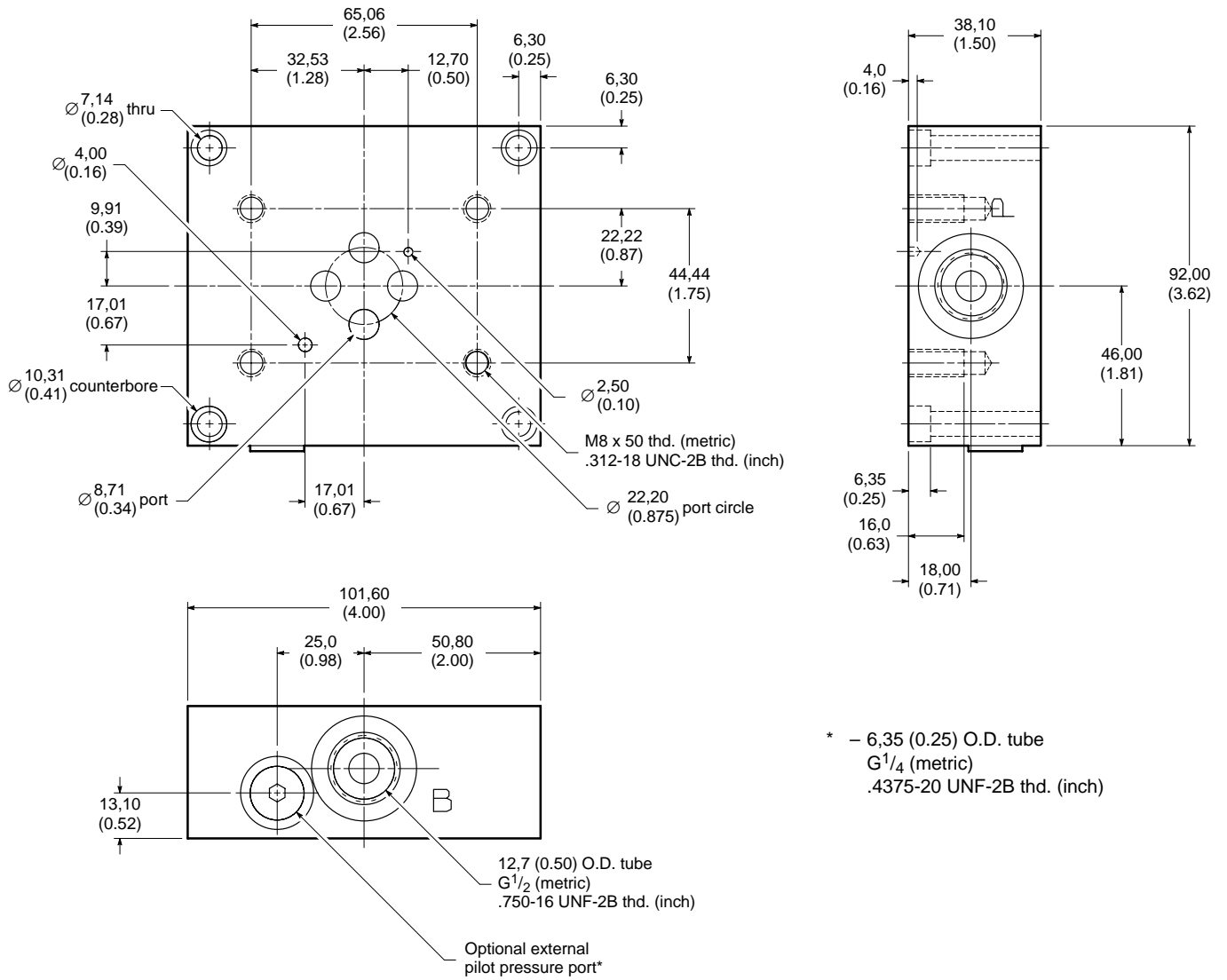

# SM4A Adapter Manifolds

## Model Code

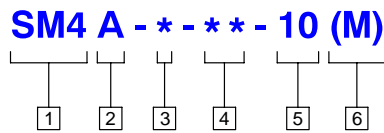

### 1 Series designation

SM4 – Servovalve, high performance, four-way (for use with SX4 or SM4 valves)

### 2 Accessory designation

A – Adapter manifold. Maximum supply pressure of 210 bar (3000 psi).

### 3 Interface

3 – ISO 4401-03 (for SM4-10/12/15)  
 5 – ISO 4401-05 (for SM4-15/20)

### 4 Standard SM4 valve size

10 – SM4-10  
 12 – SM4-12  
 15 – SM4-15  
 20 – SM4-20 or SP4-25

### 5 Design number

Subject to change. Installation dimensions same for designs 10 through 19.

### 6 Metric suffix

M – Metric version to NG (ISO) standards  
 Blank – Omit if not required

# SM4A Adapter Manifolds

## Installation Dimensions

millimeters (inches)

### SM4A-3-10-10

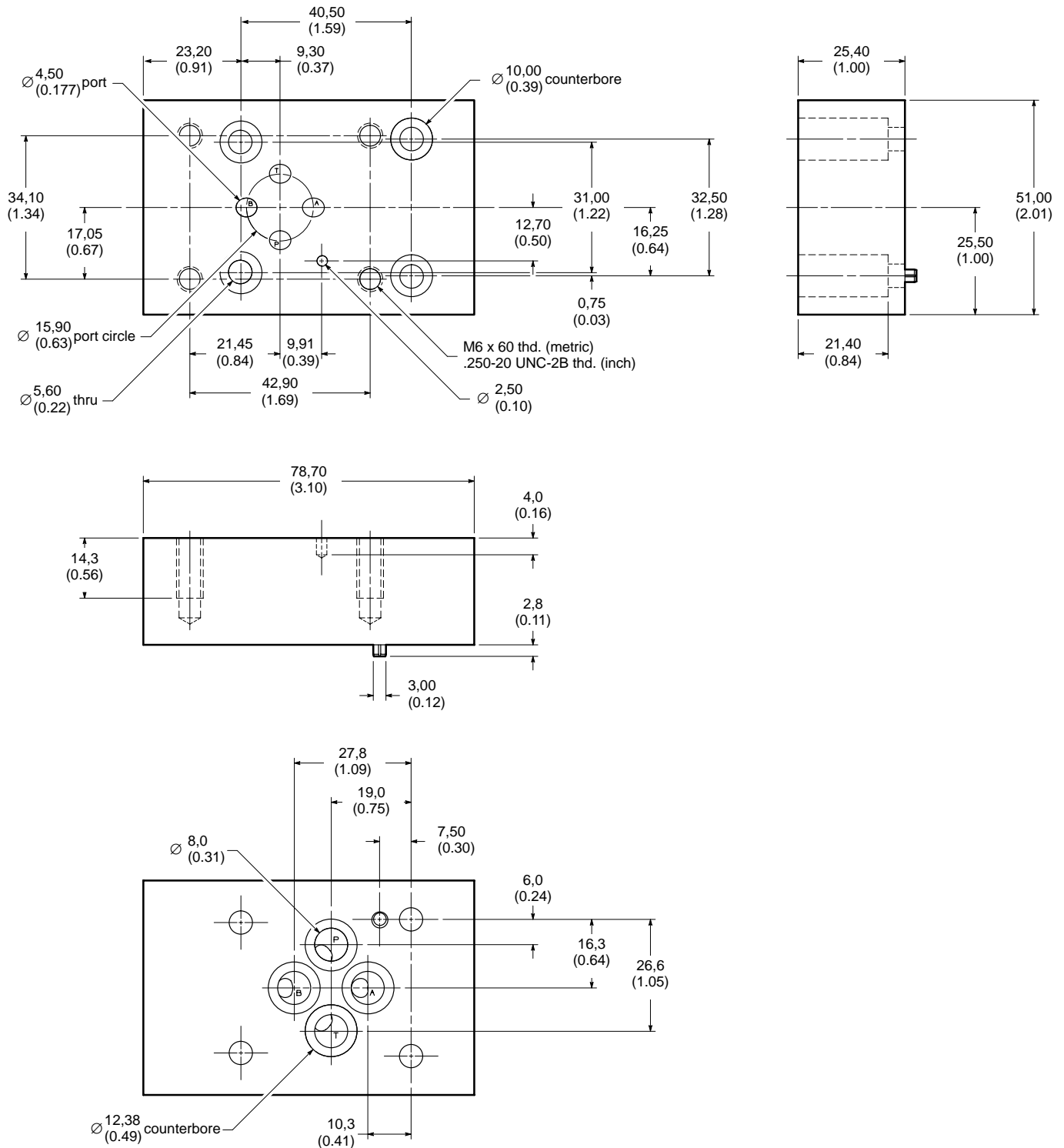

# SM4A Adapter Manifolds

## SM4A-3-12-10

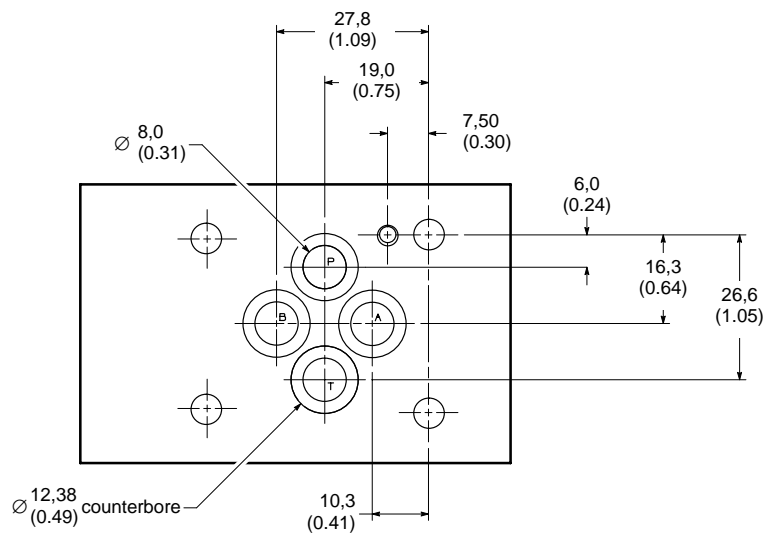
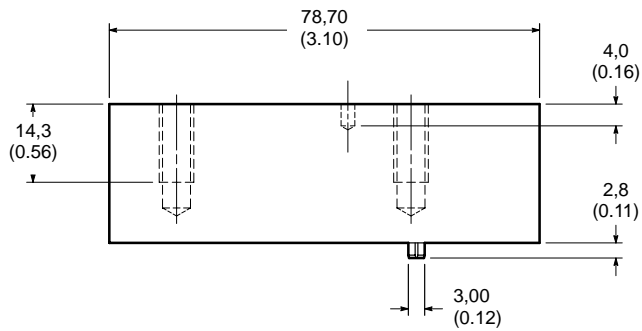
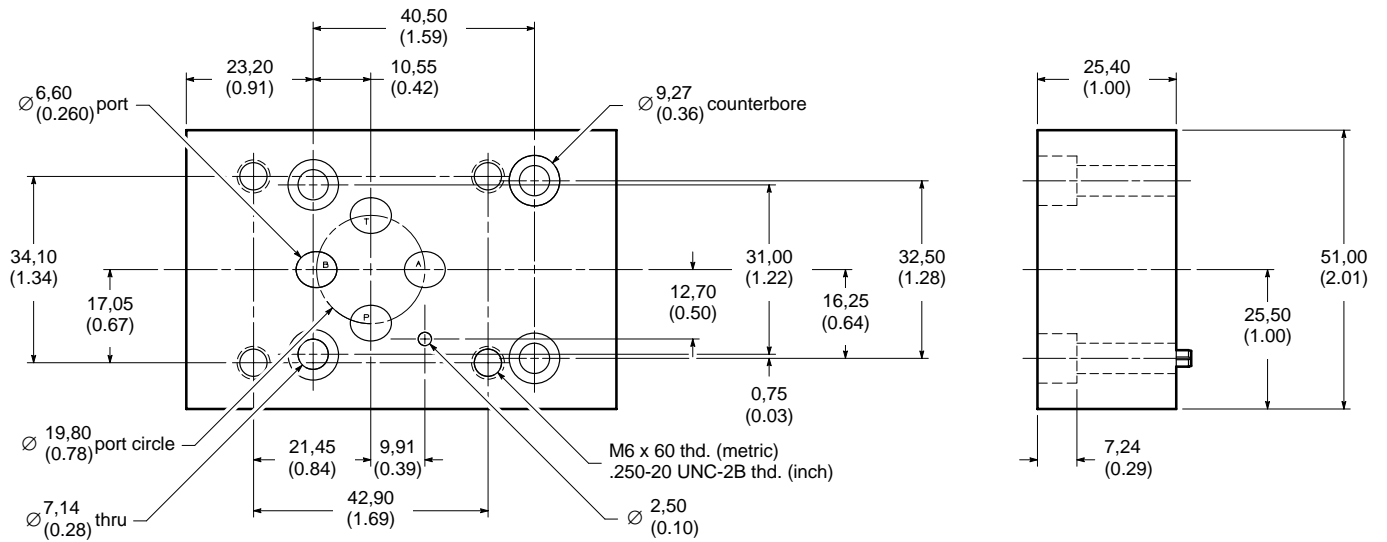

# SM4A Adapter Manifolds

## SM4A-3-15-10

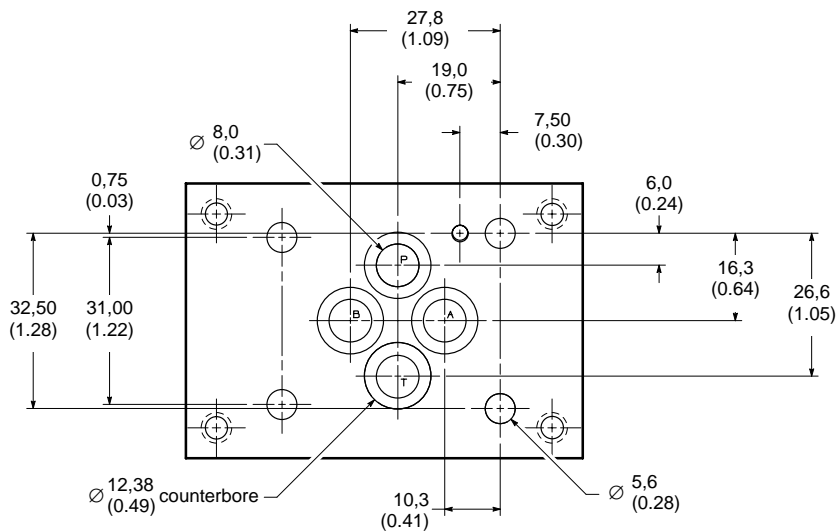
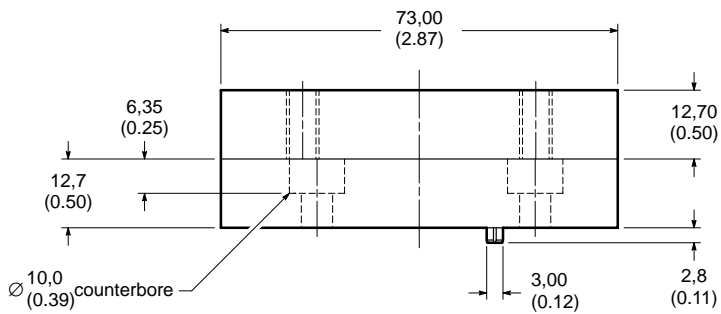
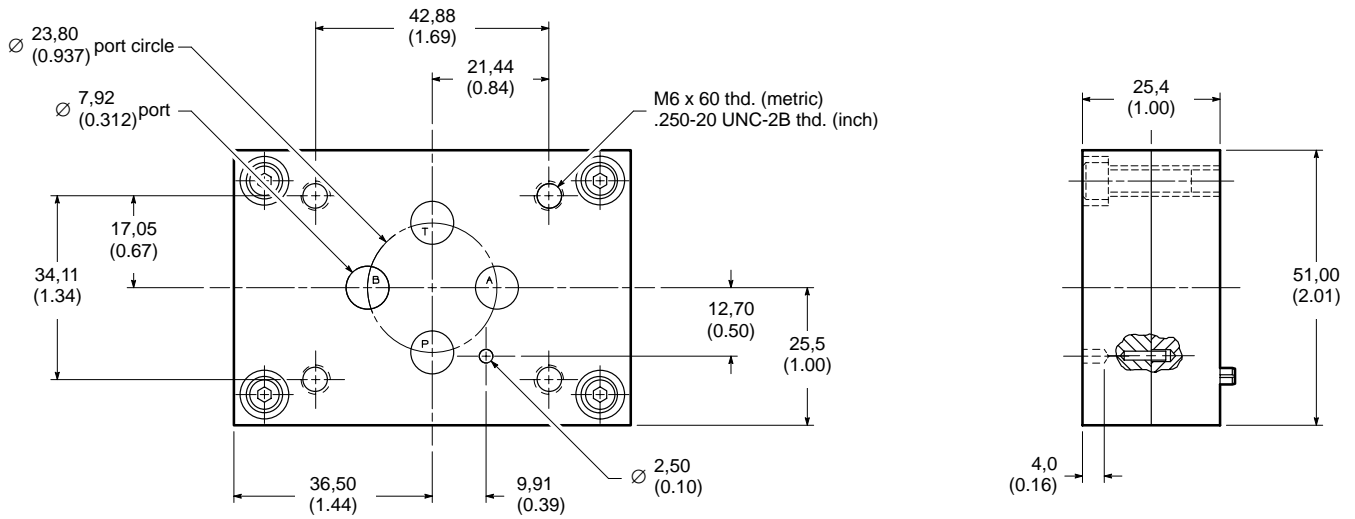

# SM4A Adapter Manifolds

## SM4A-5-15-10

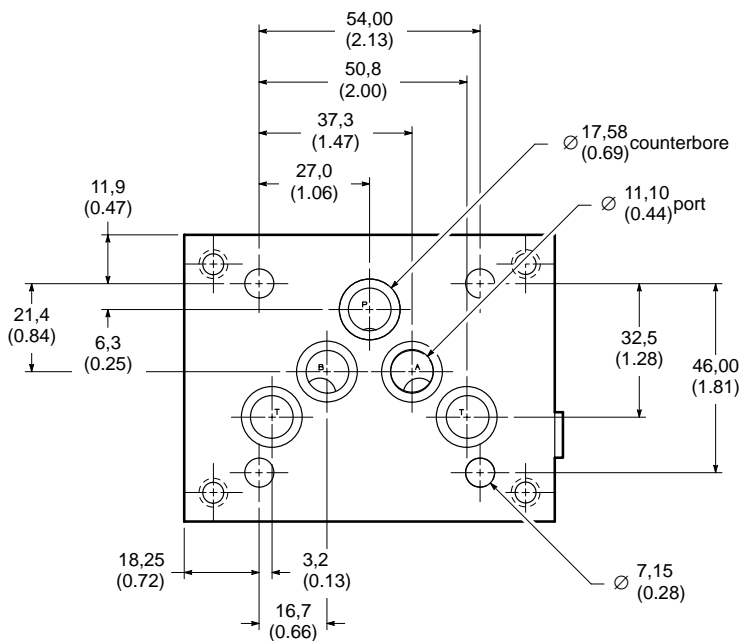
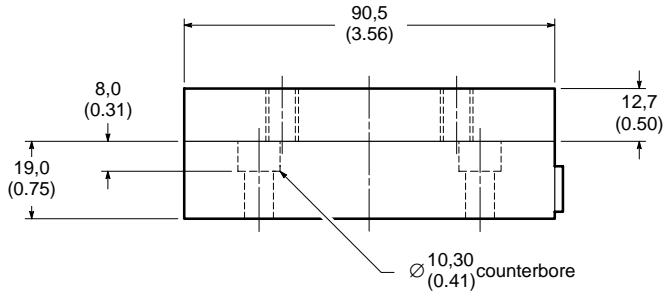
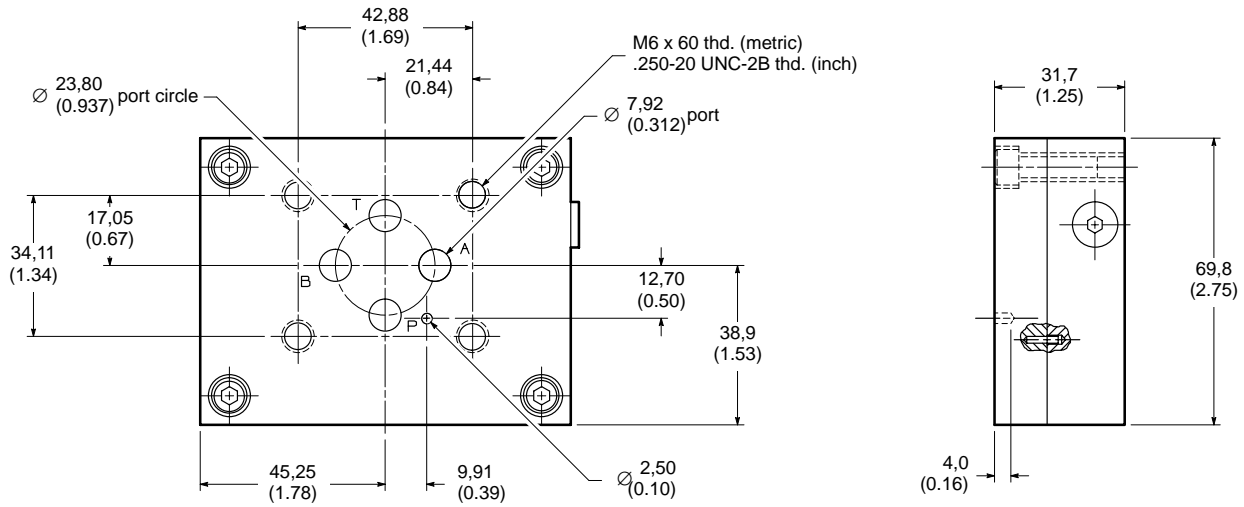



# SM4FV Flushing Valves

---

## Model Code

**SM4 FV - \* \* - 10 (M)**

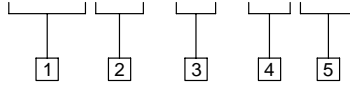

---

**1 Series designation**

SM4 – Servovalve, high performance, four-way (for use with SX4 or SM4 valves)

---

**2 Accessory designation**

FV– Flushing valve. Maximum flushing pressure of 35 bar (500 psi).

**3 Standard SM4 valve size**

10/12/15 – SM4-10  
20 – SM4-20 or SP4-25

---

**4 Design number**

Subject to change. Installation dimensions same for designs 10 through 19.

**5 Metric suffix**

M – Metric version to NG (ISO) standards  
Blank – Omit if not required

# SM4FV Flushing Valves

## Installation Dimensions

millimeters (inches)

### SM4FV-10/12/15-10

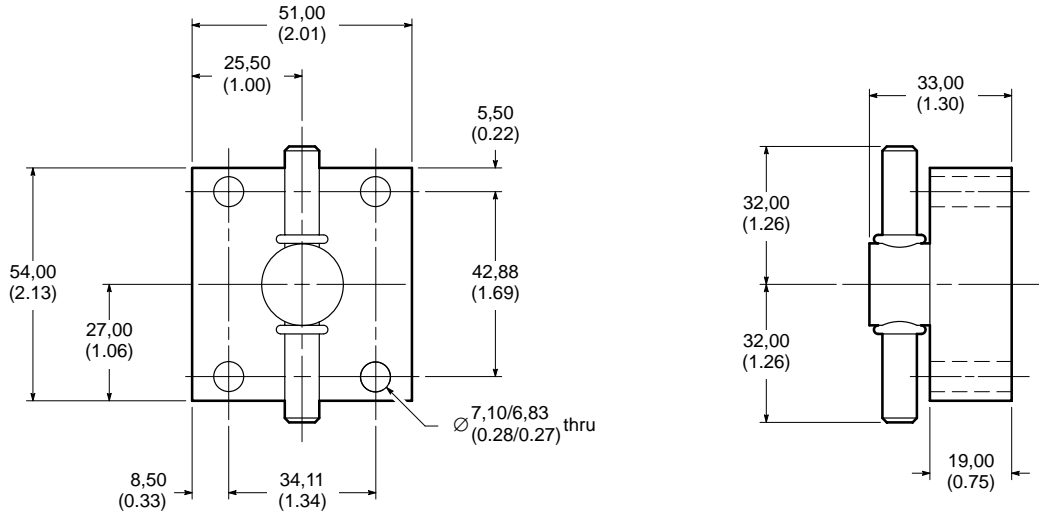

### SM4FV-20-10

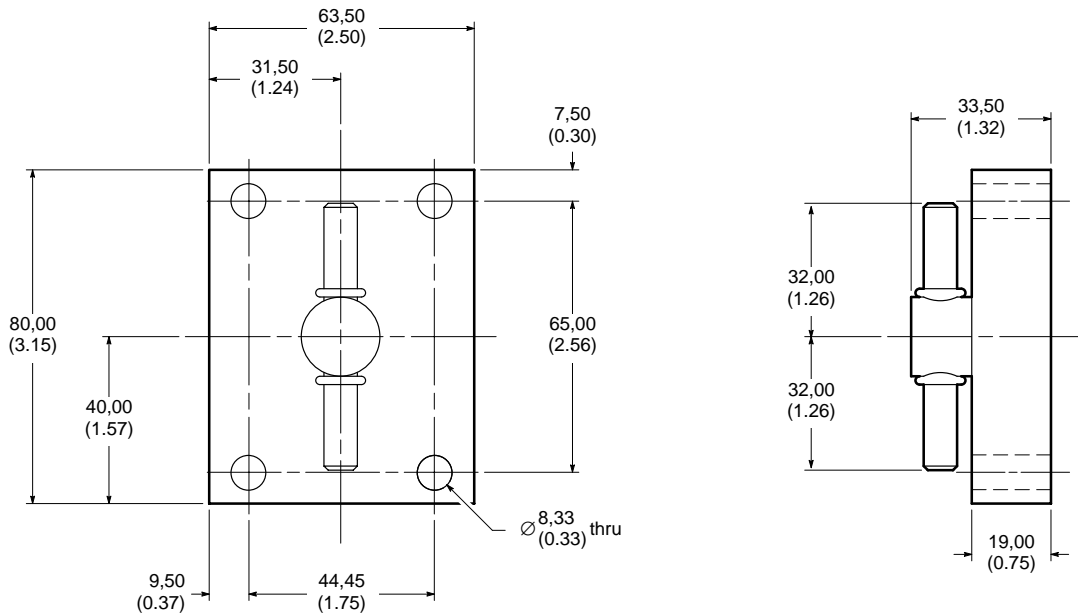

# SM4FM Filter Modules

## Model Code

**SM4 FM - 20 - (CB) - \* \***

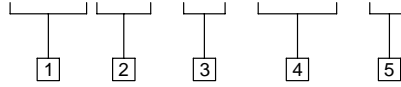

**1 Series designation**

SM4 – Servovalve, high performance, four-way (for use with SX4 or SM4 valves)

**2 Accessory designation**

FM – Filter module. Maximum supply pressure of 210 bar (3000 psi), except -5\* designs with maximum supply pressure of 350 bar (5000 psi).

**3 Standard SM4 valve size**

20 – SM4-20 or SP4-25

**4 Crossport bleed designation**

CB – Includes crossport bleed feature  
Blank – Omit if not required

**5 Design number**

Subject to change. Installation dimensions same for designs 10 through 19.

Installation dimensions also same for designs 50 through 59. Maximum supply pressure of 350 bar (5000 psi).

## Installation Dimensions

millimeters (inches)

### SM4FM-20-10

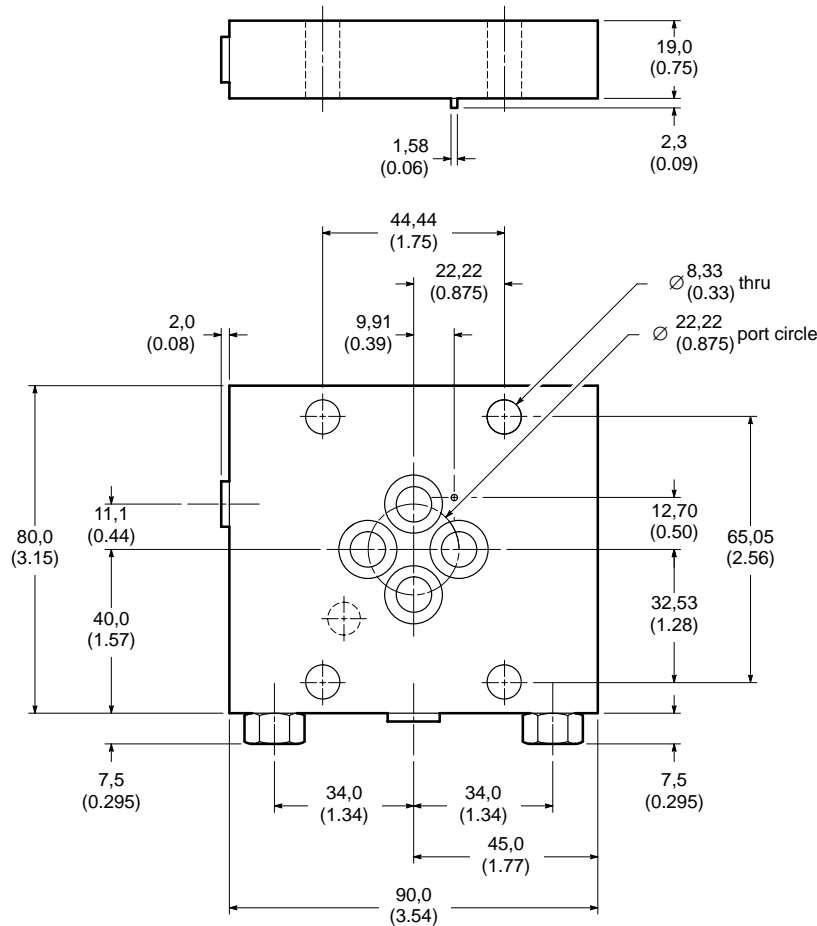

# SM4FM Filter Modules

SM4FM-20-50

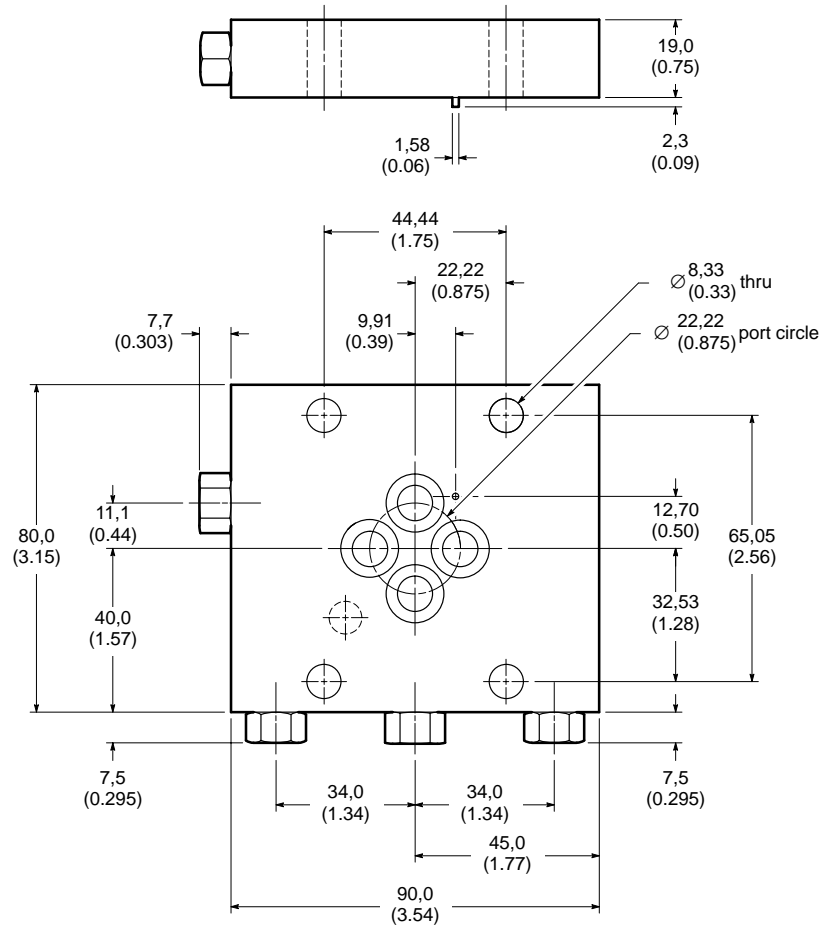

# Weights

The following table lists approximate dry weights for SX4 servovalves and related accessories.

Description	Model Code	Weight kg (lbs.)
Servovalve	SX4-10/12/15	0,73 (1.6)
	SX4-20	1,04 (2.3)
	SX4-20-V	2,18 (4.8)
Mounting subplate	SM4M(E)-10/12/15-10	0,73 (1.6)
	SM4M(E)-20-10/50	0,91 (2.0)
Adapter manifold	SM4A-3-10/12/15-10(M)	0,240 (0.53)
	SM4A-5-15-10	0,499 (1.10)
	SM4A-5-20-10/50	0,439 (0.97)
Flushing valve	SM4FV-10/12/15-10(M)	0,15 (0.32)
	SM4FV-20-10(M)	0,27 (0.58)
Filter module	SM4FM-20-50	1,04 (2.3)

## Additional Accessories

SX4-10/12/15 Accessories	Model Code
Adapter manifold, SX4-15 to 0.875 port circle (inch)	SM4A-15-M76-10
Adapter manifold, SX4-15 to 0.875 port circle (metric)	SM4A-15-M76-10M
Adapter manifold (SX4-15 to 0.875 port circle) mounting bolt kit (inch) $\frac{5}{16}$ -18 x 1 $\frac{1}{2}$ "	BK688701
Adapter manifold (SX4-15 to 0.875 port circle) mounting bolt kit (metric) M8 x 35mm	BK689630
Adapter manifold (SM4A-3-10 or SM4A-3-15) mounting bolt kit (inch) $\frac{1}{4}$ -20 x 1"	BK855984
Adapter manifold (SM4A-3-10 or SM4A-3-15) mounting bolt kit (metric) M5 x 12mm	BK855985M
Adapter manifold (SM4A-5-15) mounting bolt kit (inch) $\frac{1}{4}$ -20 x $\frac{3}{4}$ "	BK855986
Adapter manifold (SM4A-5-15) mounting bolt kit (metric) M6 x 20mm	BK855987M
Cable clamp (MS3057-6)	126058
Cable connector (MS3106-14S-2S)	242123
Connector kit	926467
Filter kit	927826
Flushing valve mounting bolt kit (inch) $\frac{1}{4}$ -20 x 1"	BK866686
Flushing valve mounting bolt kit (metric) M6 x 25mm	BK689629M
Seal kit (SX4-10)	927808
Seal kit (SX4-12)	927809
Seal kit (SX4-15)	927810

<b>SX4-10/12/15 Accessories (continued)</b>	<b>Model Code</b>
Subplate mounting bolt kit (inch) $1/4-20 \times 1\frac{1}{2}$ "	BK855992
Subplate mounting bolt kit (metric) M6 x 40mm	BK855993M
Valve mounting bolt kit (inch) $1/4-20 \times 2\frac{1}{4}$ "	BK866685
Valve mounting bolt kit (metric) M6 x 60mm	BK689623M

<b>SX4-20 Accessories</b>	<b>Model Code</b>
Adapter manifold mounting bolt kit (inch) $1/4-20 \times 1$ "	BK866686
Adapter manifold mounting bolt kit (metric) M6 x 25mm	BK689629M
Cable clamp (MS3057-6)	126058
Cable connector (MS3106-14S-2S)	242123
Connector kit	926467
Cross-port bleed module mounting bolt kit (inch) $5/16-18 \times 2\frac{3}{4}$ "	BK855421
Filter kit (SX4-20 and SX4-H-20)	927774
Filter kit (SX4-V-20 and SX4-HV-20)	927775
Filter module kit (SX4-20 and SX4-H-20)	886819
Filter module mounting bolt kit (inch) $5/16-18 \times 2\frac{3}{4}$ "	BK855421
Filter module mounting bolt kit (metric) M8 x 70mm	BK689624M
Filter module with cross-port bleed mounting bolt kit (inch) $5/16-18 \times 3\frac{1}{4}$ "	BK927736
Flushing valve mounting bolt kit (inch) $5/16-18 \times 1\frac{1}{4}$ "	BK688701
Flushing valve mounting bolt kit (metric) M8 x 35mm	BK689630M
Seal kit (SX4-20)	927776
Seal kit (SX4-H-20)	927777
Subplate mounting bolt kit (inch) $1/4-20 \times 1\frac{1}{2}$ "	BK855992
Subplate mounting bolt kit (metric) M6 x 40mm	BK855993M
Valve mounting bolt kit (inch) $5/16-18 \times 2$ "	BK866687
Valve mounting bolt kit (metric) M8 x 50mm	BK866690M

## Servo Electronics

Refer to application brochure 656 for the complete Vickers line of amplifiers, power supplies, and function modules.

# Application Data

## Fluid Cleanliness

Proper fluid condition is essential for long and satisfactory life of hydraulic components and systems. Hydraulic fluid must have the correct balance of cleanliness, materials, and additives for protection against wear of components, elevated viscosity and inclusion of air.

Essential information on the correct methods for treating hydraulic fluid is included in Vickers publication 561 "Vickers Guide to Systemic Contamination Control," available from your local Vickers distributor or by

contacting Vickers, Incorporated. Recommendations on filtration and the selection of products to control fluid condition are included in 561.

Recommended cleanliness levels, using petroleum oil under common conditions, are based on the highest fluid pressure levels in the system and are coded in the chart below. Fluids other than petroleum, severe service cycles, or temperature extremes are cause for adjustment of these cleanliness codes. Refer to Vickers publication 561 for exact details.

Vickers products, as any components, will operate with apparent satisfaction in fluids with higher cleanliness codes than those described. Other manufacturers will often recommend levels above those specified. Experience has shown, however, that life of any hydraulic component is shortened in fluids with higher cleanliness codes than those listed below. These codes have been proven to provide a long, trouble-free service life for the products shown, regardless of the manufacturer.

Product	System Pressure Level		
	psi		
	<2000	2000–3000	3000+
Vane pumps, fixed	20/18/15	19/17/14	18/16/13
Vane pumps, variable	18/16/14	17/15/13	
Piston pumps, fixed	19/17/15	18/16/14	17/15/13
Piston pumps, variable	18/16/14	17/15/13	16/14/12
Directional valves	20/18/15	20/18/15	19/17/14
Proportional valves	17/15/12	17/15/12	15/13/11
<b>Servo valves</b>	<b>16/14/11</b>	<b>16/14/11</b>	<b>15/13/10</b>
Pressure/Flow controls	19/17/14	19/17/14	19/17/14
Cylinders	20/18/15	20/18/15	20/18/15
Vane motors	20/18/15	19/17/14	18/16/13
Axial piston motors	19/17/14	18/16/13	17/15/12
Radial piston motors	20/18/14	19/17/13	18/16/13